



DHG



SLG



ISLG



SHG

Take the "grind" out of grinding coffee beans with Curtis Portion Control Coffee Grinders.

Available in Full-Size and Low-Profile Single Hopper and Dual Hopper models, these superior grinding systems feature fully automatic operation. A host of intelligent design features

are incorporated to give you the most efficient, dependable and easy-to-operate coffee grinders you can buy.

A Warranty That Out-Performs The Rest.



ILG

Performance Features

Unmatched By Any Other Grinder

- Fully Automatic Operation.
- Solid State, Dual Range Timers - Ensures precise portion control in all portion sizes.
- Models ILG & ISLG "Interlock" with Gemini Systems - To create a fool-proof fresh-grind/fresh-brew coffee center.
- Infinitely Adjustable Grind Settings - From extra-coarse to extra-fine grinding.
- Fully Adjustable Portion Size - 1 oz. to 27 oz. (20 oz. on ILG and ISLG).
- Larger Hopper Capacity than Competitive Models - Reduces labor costs with less frequent refills.
- Full-Size Models:
SHG: Single 6 lb. Hopper
DHG/ILG: Dual 7.5 lb. ea. Hopper
- Low-Profile Models:
SLG: Single 5 lb. Hopper
ISLG: Single 5 lb. Hopper
- One-Button Grinding - Automatically stops when portion is fully distributed
- Dual Hopper Models - Lighted select/start buttons begins grinding process as hopper is selected. No "two step" process!

- Single Hopper Models - Single select/start switch.
- Positive Flow Auger - For uninterrupted coffee dispensing.
- Self-Adjusting Brew Rails - Easily handle large Gemini brew baskets and all other basket models and sizes.
- Gemini Match Profile - Wider base than competitive models. Brew rails never extend beyond housing with larger baskets.
- Large Grinding Burrs - Provide faster more efficient operation.
- Highly Accurate and Consistent Throw - For even distribution, dust reduction.
- Uniform Grind.
- Powerful 1/2 hp Motor - Equipped with safety circuit breaker.
- Standard 120VAC Operation.

40
40

Curtis Provides the Best Coffee Grinder Warranty in the Business... Full One-Year Warranty on all components...and 40 months or 40,000 lbs. of coffee on grinding burrs.



THE Betty Mills COMPANY
Fast & Friendly Service is our Business

SHG

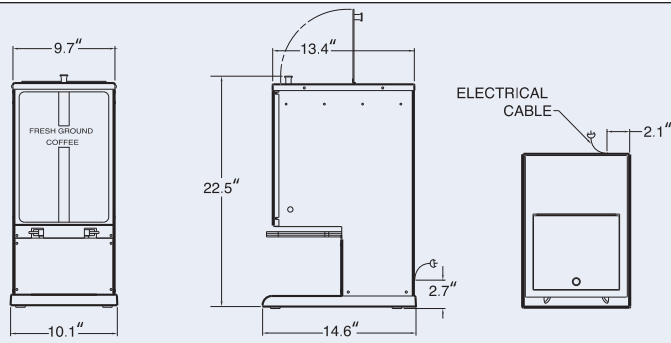

DHG ILG

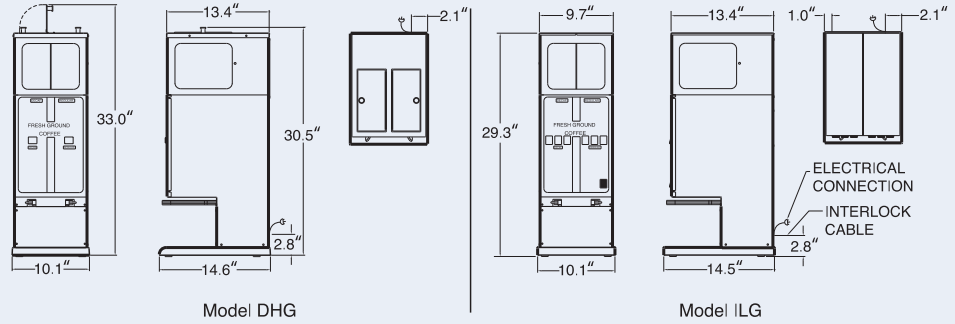

SLG ISLG

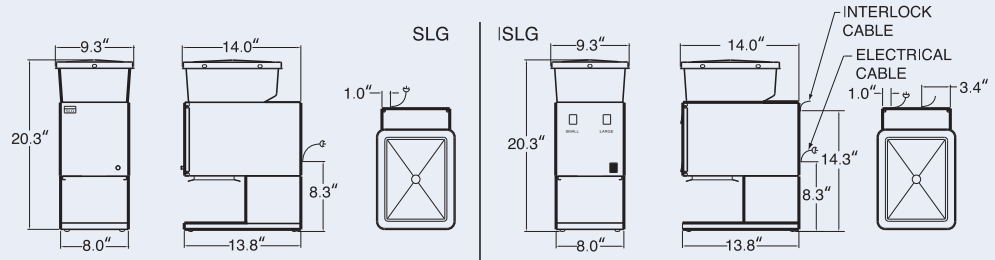

SPECIFICATIONS	SHG	DHG	ILG	SLG	ISLG
Hopper Capacity (Whole Beans)	6 lbs	7.5 lbs ea. side	7.5 lbs ea. side	5 lbs.	5 lbs.
Timer	Dual Range/Solid State	Dual Range/Solid State	Solid State Interlock	Dual Range/Solid State	Solid State Interlock
Portion Range	1 oz. to 27 oz.	1 oz. to 27 oz.	1 oz. to 27 oz.	1 oz. to 27 oz.	1 oz. to 20 oz.
Dimensions (H x W x D)	22.5" x 10.1" x 14.6"	30.5" x 10.1" x 14.6"	29.3" x 10.1" x 14.5"	20.3" x 8.0" x 13.8"	20.3" x 8.0" x 13.8"
Voltage	120VAC/60Hz	120VAC/60Hz	120VAC/60Hz	120VAC/60Hz	120VAC/60Hz
Power Requirements	8.0A	8.0A	8.0A	8.0A	8.0A
Motor	.5 hp	.5 hp	.5 hp	.5 hp	.5 hp
Weight (lbs.)	42	52	52	43	43
Shipping Weight (lbs.)	47	58	58	44	44
Cube (cu. ft.)	3.3	4.4	4.4	3.3	3.3



The Betty Mills Company
 2121 El Camino Real
 Suite D-100
 San Mateo, CA 94403
 800.238.8964
 www.BettyMills.com

