



ASSEMBLING THE AIRPOT RACK

MODELS: CAR-2, CAR-3, CAR-4, CAR-6

Thank you for selecting this quality Curtis product. A few minutes of assembly is all that's required to set up this airpot rack for use. The tools you will need are a slotted screwdriver and a small adjustable wrench.

The following steps will guide you through the assembly process.

1. Unpack the box, being careful not to misplace any of the parts.

2. Install the rubber feet (4 feet on single row racks 6 feet on step-up racks). Take the threaded portion and push it in through the hole from the bottom of the rack. From inside the frame, fasten the rubber feet with the acorn nuts. Hold the nut with an adjustable wrench or pair of pliers while twisting the foot to tighten.

3. Install the sign holder. On step-up racks, there is a separate sign holder for the back row of airpots. Place it against the back of the rack. Align the holes on the rack with the holes on the sign holder. Insert the slotted screws, (two provided) to fasten and secure with the acorn nuts.

4. Place the drip trays into the shelves built into the racks.

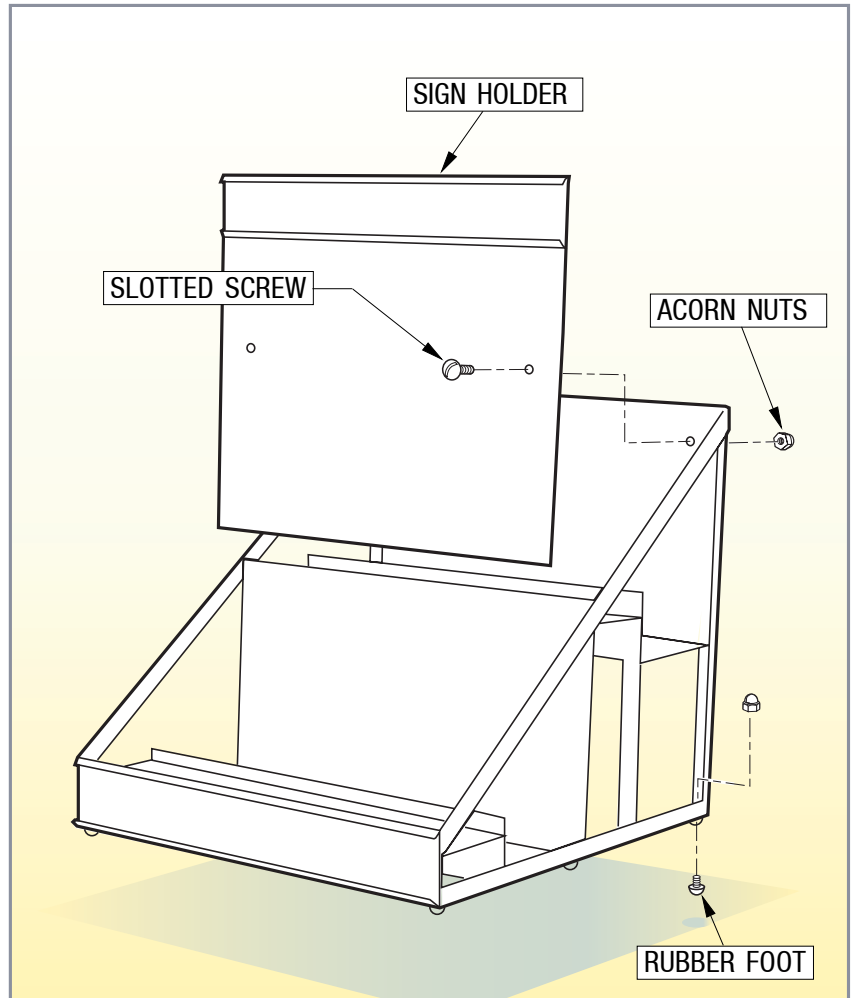

WILBUR CURTIS COMPANY, INC.

6913 Acco Street, Montebello, CA 90640-5403 • Telephone: 800-421-6150 • 323-837-2300 • Fax: 323-837-2406

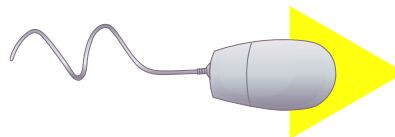

find the latest on the web at
www.wilburcurtis.com