

Storage Shed

Patent #416.091

OWNER'S MANUAL / Instructions for Assembly Size 8' x 6'

Ver: 2.0

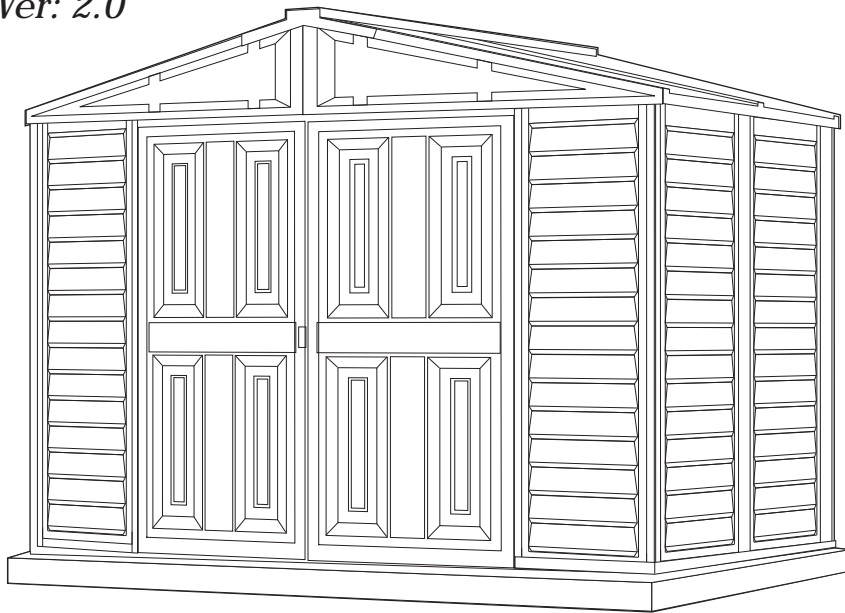

**Customer
Service Hotline
(800) 483-4674
www.uspolymersinc.com**

Your Total Solution To maintenance Free Storage Sheds.

- All Weather Durable PVC
- Won't Dent, Rust, Rot or Mildew
- Never Needs Painting
- 61" Wide Double Doors
- Easy Assembly
- High Wind Tested
- Snow Load Tested 20lbs/sq.foot
- Pad Lock Ready (Lock not included)
- Wooden or Cement Foundation Needed

Requires two people and takes about
3-4 hours for Installation.

Available Kits

- Foundation Kit Available
- Modular 2.5' Extension Kits Available
- 8'x6' Window Kits Available

Call us for any missing or damaged parts.
Do not return to the store.

Parts List

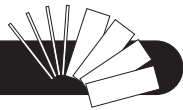

Note: Check all parts prior to installation.

CODE	DESCRIPTION	QTY
B1LB	FRONT 'U' CHANNEL LEFT	1
B1RB	FRONT 'U' CHANNEL RIGHT	1
B2B	SIDE 'U' CHANNEL	2
B21	BACK 'U' CHANNEL LEFT	1
B22	BACK 'U' CHANNEL RIGHT	1
CMB	MIDDLE COLUMN	4
CCB	CORNER COLUMN	4
CDLB	LEFT DOOR COLUMN	1
CDRB	RIGHT DOOR COLUMN	1
CB1B	FRONT CENTER BAND	2
CB2B	SIDE CENTER BAND	2
CB3B	BACK CENTER BAND SHORT	1
CB3XB	BACK CENTER BAND LONG	1
CB4B	FRONT CROSS CENTER BAND	2
RS1XB	RS1 ROOF STRUCTURE	4
RS2B	RS2 ROOF STRUCTURE	4
RS3B	RS3 ROOF STRUCTURE	2
RS4XB	RS4 ROOF STRUCTURE	2
RS5B	RS5 ROOF STRUCTURE	4
RS8B	RS8 ROOF STRUCTURE SUPP. LONG	4
RS9B	RS9 ROOF STRUCTURE SUPP. SHORT	4
MJ	MIDDLE JOINING SUPPORT	3
RS10B	RS10 ROOF STRUCTURE SUPPORT	2
RS11B	RS11 ROOF STRUCTURE SUPPORT SHORT	1
RS12B	RS12 ROOF STRUCTURE SUPPORT LONG	1
RS14B	SAGGING SUPPORT	8
DSH	DOOR STOPPER HORIZONTAL	1
SP^	SIDE PANEL	7
FPLB	FACIA PANEL LEFT	2
FPRB	FACIA PANEL RIGHT	2
RP^	ROOF PANEL	4
RRS	RIDGE COVER	2
DL	LEFT DOOR	1
DR	RIGHT DOOR	1
FSP^	FRONT SIDE PANEL	2

ACCESSORIES

CODE	DESCRIPTION	QTY
FDCL	DOOR COLUMN FITTING LEFT	1
FDCR	DOOR COLUMN FITTING RIGHT	1
FCC	CORNER COLUMN FITTING	4
FMC	MIDDLE COLUMN FITTING	4
FCB	CENTER BAND FITTING	4
RJ	90 DEGREE JOINT	4
PPG	ROOF PLUG w/WASHER	64
PIN	ROOF PIN	64
EPS	END PLUG SQUARE	4
CBC	CENTER BAND COVER	1
S1	DIA. 4.2 x 16mm. (5/32" x 5/8") SHEET METAL SCREW	168
S2	DIA. 4.2 x 32mm. (5/32" x 1 1/4") SHEET METAL SCREW	8
S7	DIA. 4.2 x 10mm. (5/32" x 3/8") SHEET METAL SCREW	8

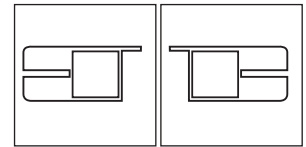

LEFT DOOR COLUMN (CDLB) RIGHT DOOR COLUMN (CDRB)

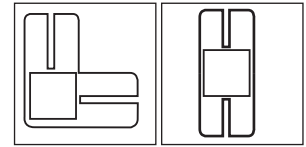

CORNER COLUMNS (CCB) MIDDLE COLUMNS (CMB)

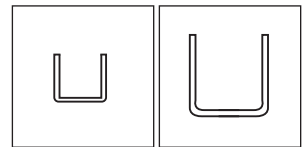

ROOF STRUCTURES (RS-1XB, 3B, 8B, 9B) U-Channels (B1LB)(B1RB) (B21) (B22) (B2B)
(CB-1B, 2B, 3B, 3XB, 4B), (MJ)

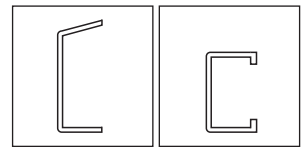

ROOF STRUCTURE (RS5B) DOOR STOPPER (DSH)

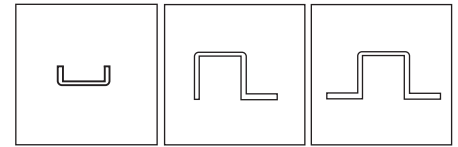

SAGGING SUPPORT (RS14B) ROOF SUPPORT (RS2B) (RS10B) ROOF SUPPORT (RS4XB) (RS11B) (RS12B)

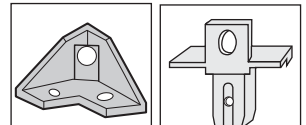

CENTER BAND FITTING (FCB) MIDDLE COLUMN FITTING (FMC)

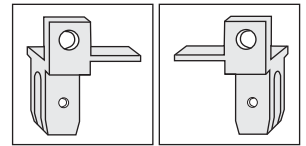

DOOR COLUMN FITTING (FDCL) DOOR COLUMN FITTING (FDCR)

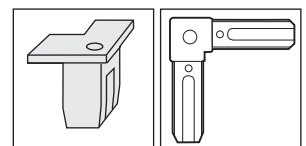

CORNER COLUMN FITTING (FCC) PVC 90 DEGREE JOINT (RJ)

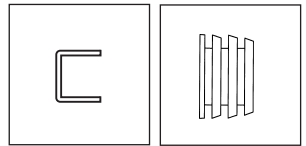

CENTER BAND COVER (CBC) END PLUG SQUARE (EPS)

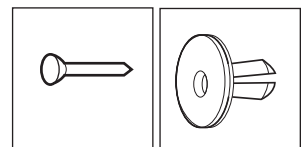

ROOF PIN (PIN) ROOF PLUG WITH WASHER (PPG)

Tools You Will Need

- Cordless Drill - Philips Head
- Hammer or Rubber mallet
- Carpenters Square
- 8' Step Ladder
- Adjustable pliers
- Level - 3ft.
- Tape Measure
- Caulk Gun
- Waterproof Clear Silicon
- Sealant
- Hand Gloves

8' x 6' Exploded View

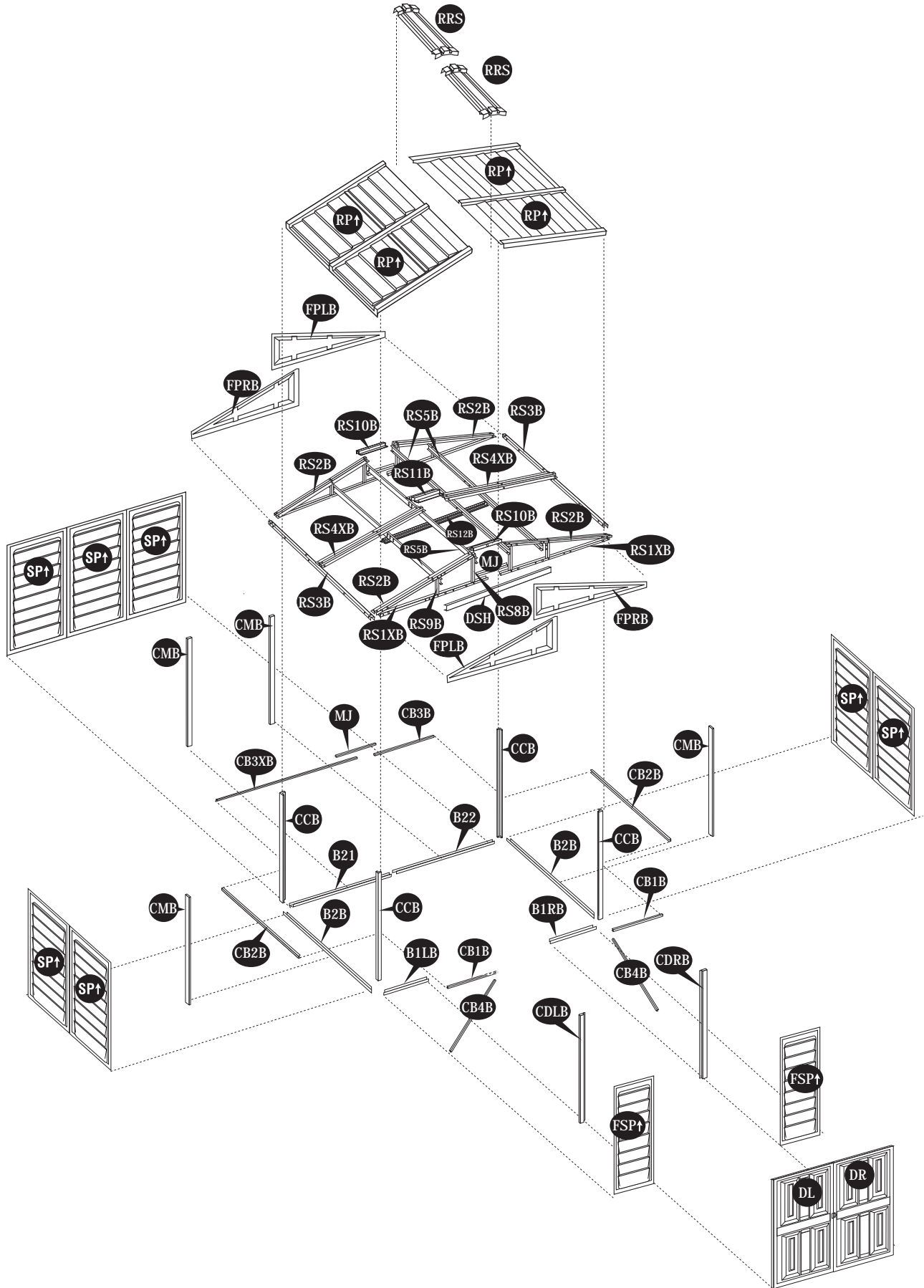
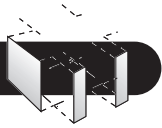

Duramax Storage Shed Limited Fifteen Year Warranty

U.S. Polymer Inc. will send a replacement part free of charge, in the event of material defects and or workmanship for a period of fifteen years from the date of purchase.

This warranty is extended only to the original purchaser. A purchase receipt or other proof of date of original purchase will be required before warranty service is rendered. In no event shall we pay the cost of flooring, labor, installation or any other costs related thereto.

This warranty only covers failures due to defects in material or workmanship which occurs during normal use and does not extend to color change arising due to normal weathering or to damage resulting from misuse or neglect, commercial use, failure to follow assembly instructions and the owner's manual (including proper anchoring of the shed), painting, forces of nature and other causes which is beyond our control.

Claims under this warranty must be made within the warranty period by calling 1-800-483-4674 or mail in a dated sales slip and clear photograph of the part to:

U.S. Polymers, Inc.
6915 Slauson Avenue
Commerce, CA 90040

We reserve the right to discontinue or change components. If a component has been discontinued or is not available,

U.S. Polymers, Inc. reserves the right to substitute a component of equal quality as may be compatible.

Limits and Exclusions

There are no express warranties except as listed above. The warrantor shall not be liable for incidental or consequential damages resulting from the use of this product, or arising out of any breach of this warranty.

All express warranties are limited to the warranty period set forth above. Some states do not allow the exclusion or limitation on how long an implied warranty lasts, so the above limitations may not apply to you.

This warranty gives you specific legal rights and you may also have other rights which vary from state to state or country to country.

A. Foundation & Base Frame

Note: It is important that these instructions are followed step by step.

DuraMax must be installed on a level wooden platform or a level concrete foundation.



Wooden platform is extra and is not included. Don't install under windy conditions.

Parts needed:

- (1) U channel Front left (B1LB)
- (1) U channel Front right (B1RB)
- (1) U channel Back (B21)
- (1) U channel back (B22)
- (2) U channel Side (B2B)
- (22) Dia. 4.2 x 16mm Screws (S1)

1. Use pressure treated wood studs 2" x 4" (5cm x 10cm) to build a foundation structure that has an outside dimension of 65" x 96" (1651mm x 2438.4mm).

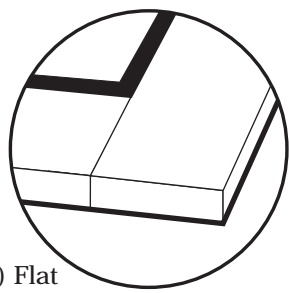

Lay 2"x4" (5cm x 10cm) Flat

2. Using exterior grade CDX 3/4" (19mm) plywood, cut and fit together the sheets to form solid plywood floor as shown. Foundation must be square and level.

Wooden Platform (Not Included)

The following are a list of lumber and sizes you will need.

- | | |
|---|--|
| Pressure Treated - Wood Studs: | Exterior Grade (CDX): |
| 4ea 2" x 4" x 89" (50 x 88.9 x 2260.6 mm) | 3/4" 19mm plywood |
| 2ea 2" x 4" x 65" (50 x 88.9 x 1651 mm) | 1ea 3/4" x 48" x 96" (19 x 1219.2 x 2438.4 mm) |
| | 1ea 3/4" x 17" x 96" (19 x 431.8 x 2438.4 mm) |

L-Brackets: 4ea

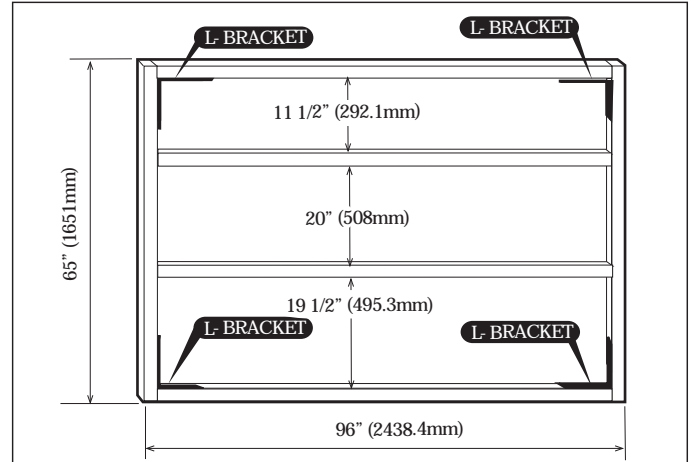

Foundation Structure

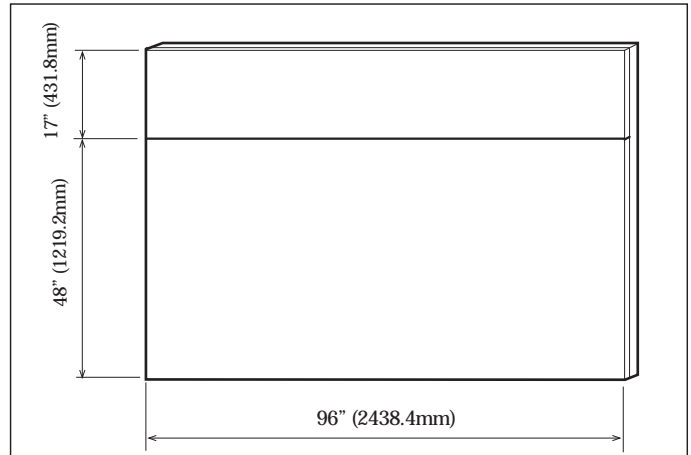

Plywood Floor

3. Start with U-Channel bases (B21) & (B22) to insure a quick and accurate layout. Position all bases (B1LB, B1RB, B2B) on wood foundation. It is critical that you allow 61 1/4" (1556mm) between front bases (B1RB) and (B1LB) for door placement. Measure in all directions as shown in fig.1. Make sure the U-channel assembly is a perfect square.

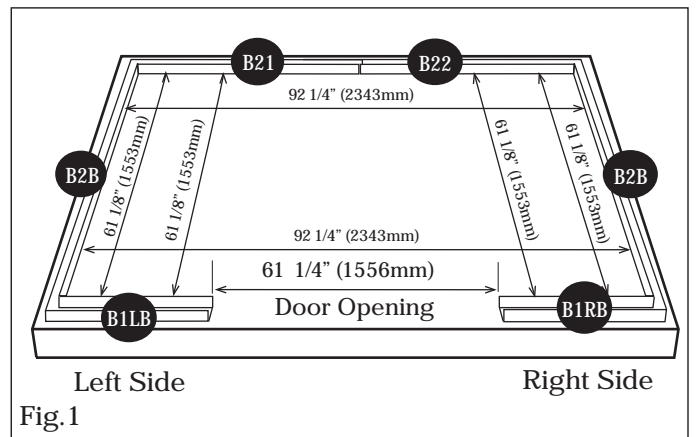

Fig.1

U-Channel Layout

4. Using a carpenter's square, line up all corners. Secure base to wood foundation using (S1) screws

Concrete foundation

4b. Shed or shed foundation should be placed on concrete footing by use of anchor bolt and nut. Using a carpenter's square, line up corners. Align U-Channel base, mark the concrete through the holes in the base and drill concrete with 1/2" (dia. 12.5mm) concrete bit to accept anchor bolts to a 1 3/4" (44mm) depth. Replace base and secure with 1/4" x 1 1/2" (M6 x 40mm) anchor bolts. (not provided)

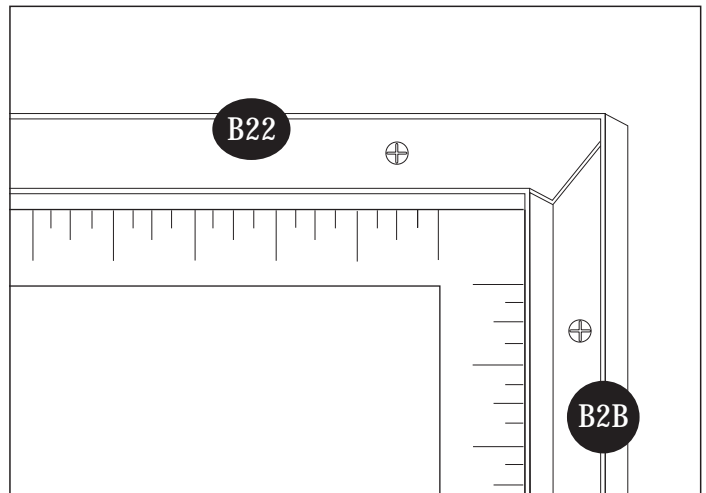

B. Walls & Columns

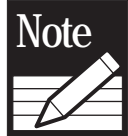

All panels are clearly marked and care should be taken to use the correct one.

Parts Needed:

- | | |
|-----------------------------|---------|
| (4) Corner Column | (CCB) |
| (1) Left Door Column | (CDLB) |
| (1) Right Door Column | (CDRB) |
| (4) Middle Column | (CMB) |
| (7) Side Panels | (SP†) |
| (2) Front Side Panels | (FSP†) |
| (2) Front Center Band | (CB1B) |
| (2) Side Center Band | (CB2B) |
| (1) Back Center Band short | (CB3B) |
| (1) Back Center Band long | (CB3XB) |
| (2) Front cross center band | (CB4B) |
| (1) Middle Joining Support | (MJ) |
| (4) Center Band Fitting | (FCB) |
| (1) Center Band Cover | (CBC) |

1. Slide right door column (CDRB) into the U-Channel Base (B1RB) on the right side of the door. Line up the pre-drilled holes on (CDRB) Column with pre-drilled holes on U-Channel Base. Secure with two (S1) Screws from inside. (See blowup detail fig.1)

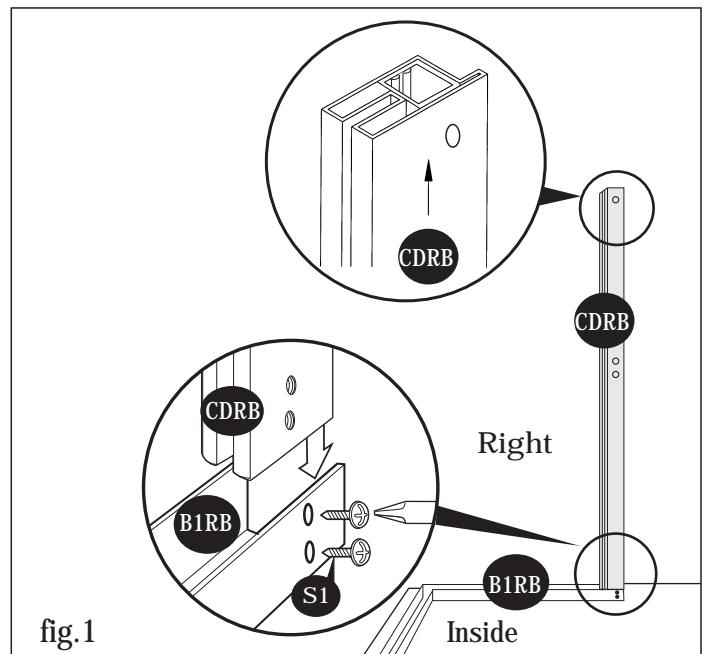

2. Insert the front side panel (FSP↑) into the groove of column (CDRB). Start at the bottom of the panel at an angle then push into place.

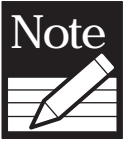

Always place panels into frame at an angle on top and slide in sideways and downward for easy insertion.

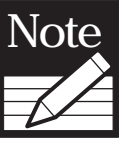

Make sure panels are right side up with panel shingles facing down. Check the stamped label on top of all panels.

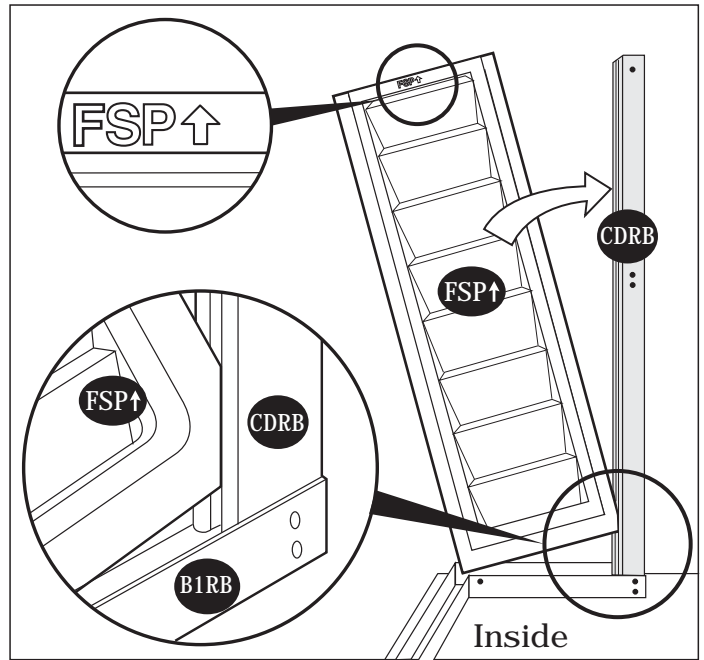
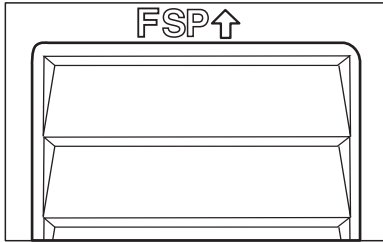

3. Slide corner column (CCB) into side panel (FSP↑) pushing the column to the side panel.

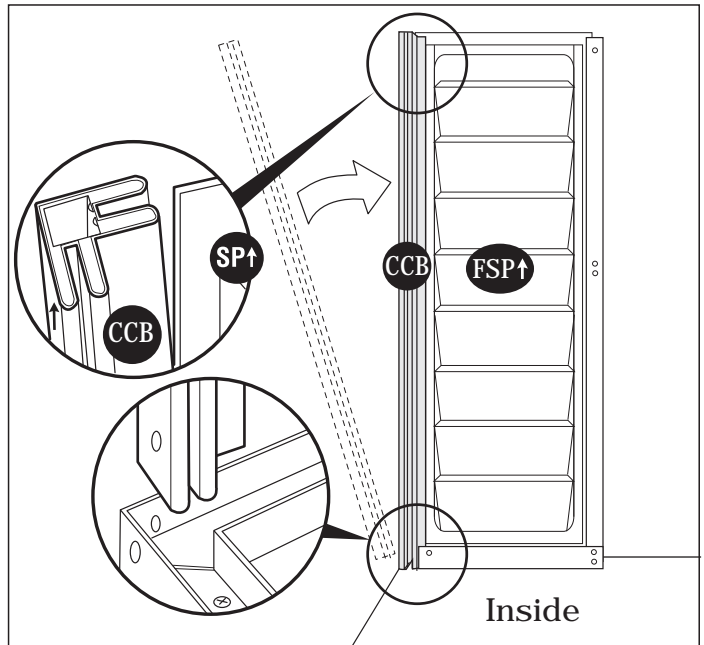

4. Working outside use (S1) screws to secure column to bases (B1RB) and (B2B).

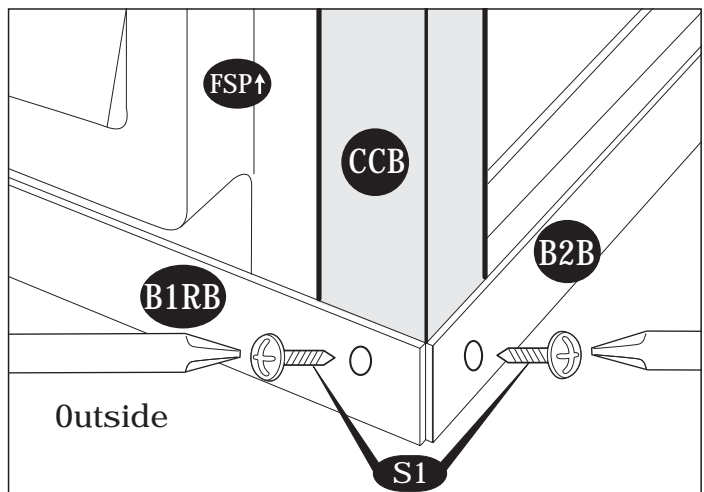

5. To stabilize the front panel attach the front center band right (CB1B). Start with the center band fitting. Fix to corner column (CCB) with (S2) screws. To continue See figures (fig.1) (fig.2) and (fig.3).



To insure easy assembly Locate the identification number of each part.

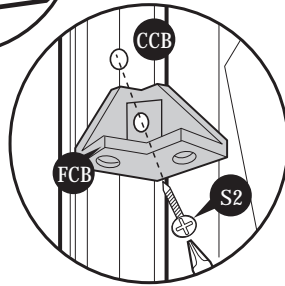
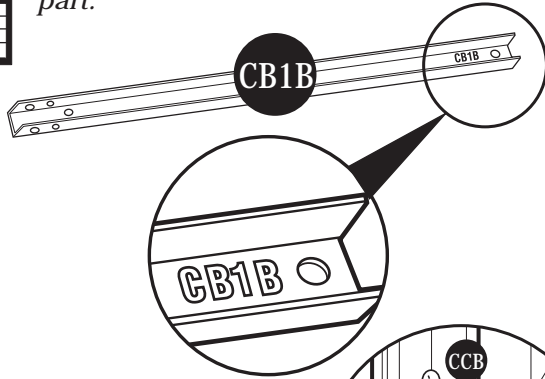

Fig. 1: Use (S2) screw. Fix (FCB) to (CCB). Leave it loose.

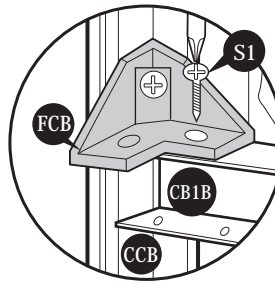

Fig. 2: Use (S1) screw. Fix (CB1B) to (FCB).

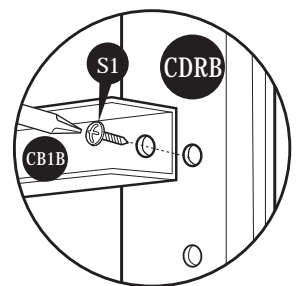
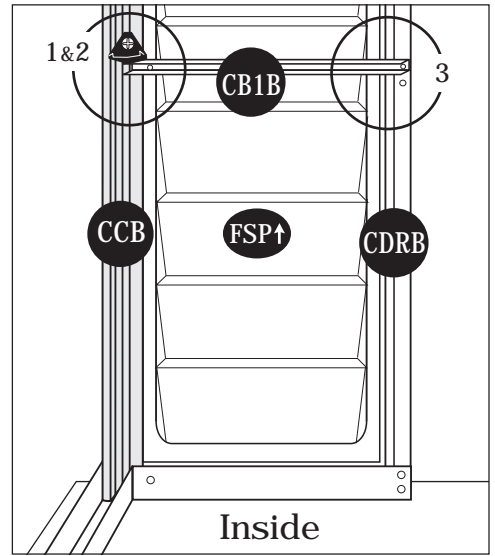

Fig. 3: Use (S1) screw. Fix (CB1B) to (CDRB).



6. Attach center band (CB4B) to door column (CDRB) and base channel (B1RB).

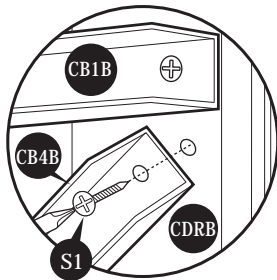

Fig. 1: Use (S1) screw. Fix (CB4B) to (CDRB)

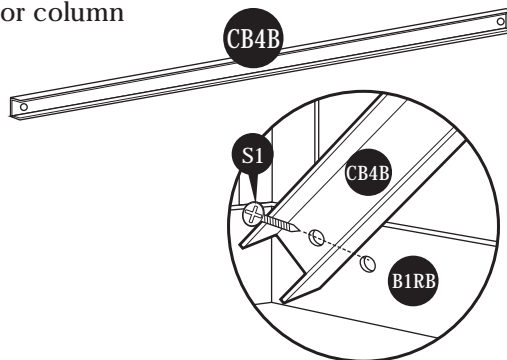

Fig. 2: Use (S1) screw. Fix (CB4B) to base (B1RB)

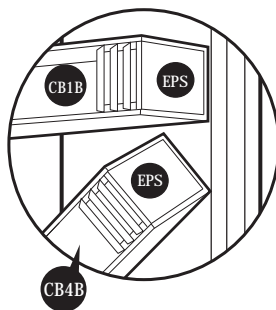
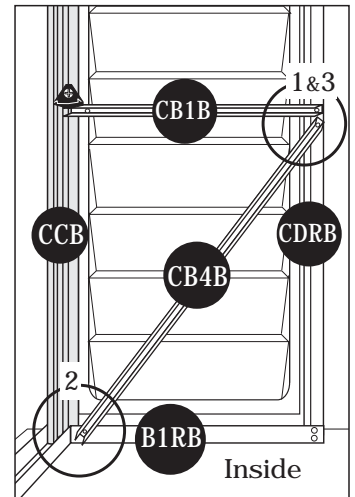
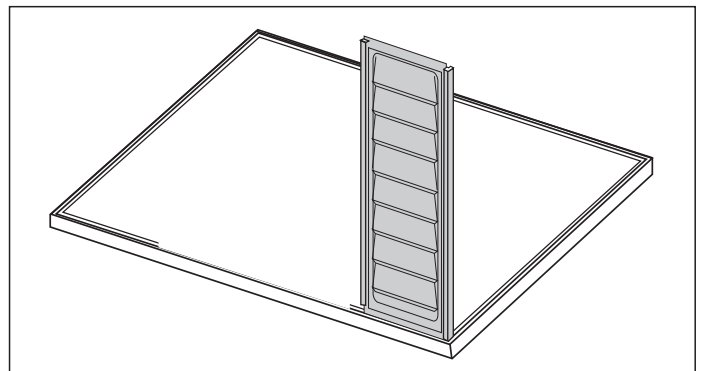
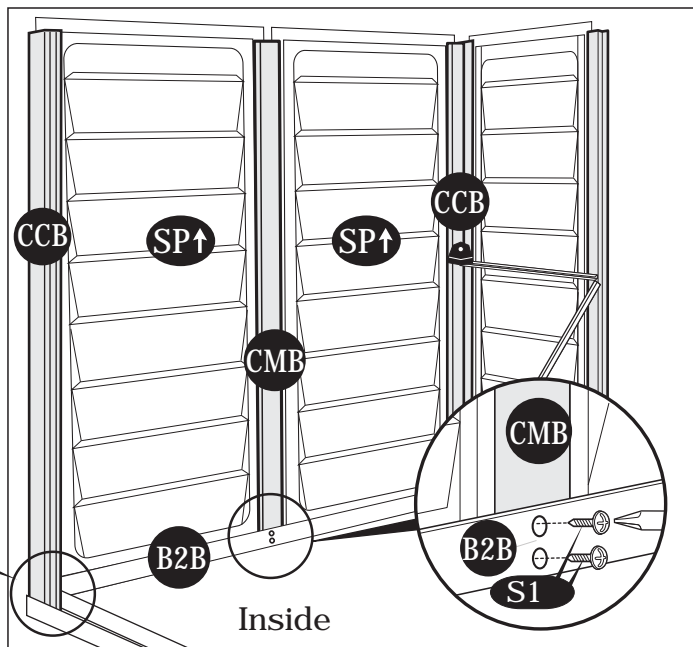
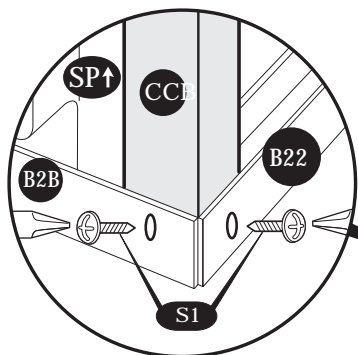

Fig. 3: Fix the (EPS) at the end of (CB1B) & (CB4B).



7. Working from inside, continue connecting the 2 side panels (SP↑) and column (CMB) in sequence along (B2B) base to corner column (CCB). Use (S1) screws to fix columns to base.



8. Stabilize the side panels with center band (CB2B). Start with the center band fitting (FCB). Fix to corner column (CCB) with (S2) screws. See figures (fig.1) (fig.2) (fig.3) and (fig.4).

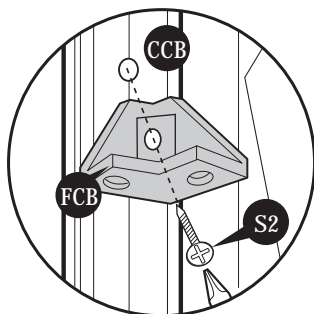

Fig.1: Use (S2) screw. Fix (FCB) to (CCB). Leave it loose.

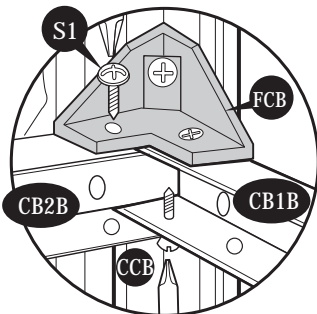

Fig.2: Use (S1) screws. Fix (CB2B) to (FCB) and (CB1B)

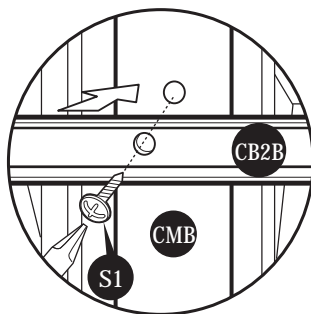
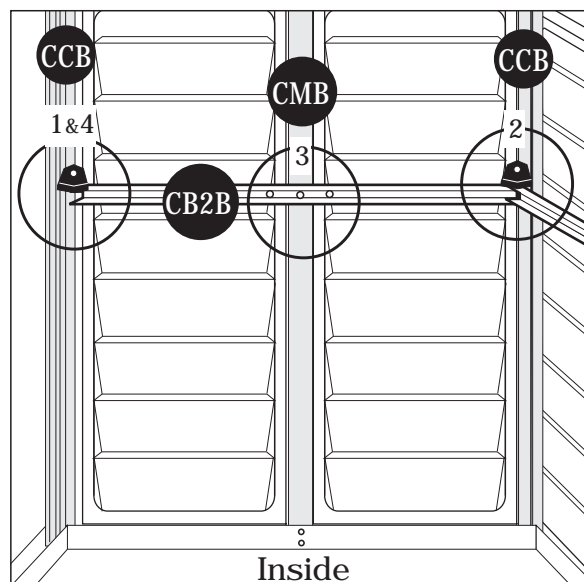

Fig.3: Use (S1) screws. Fix (CB2B) to (CMB).

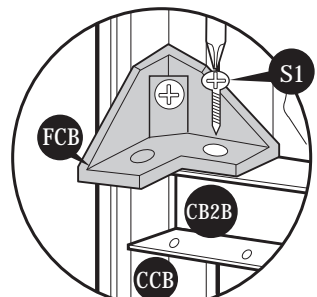
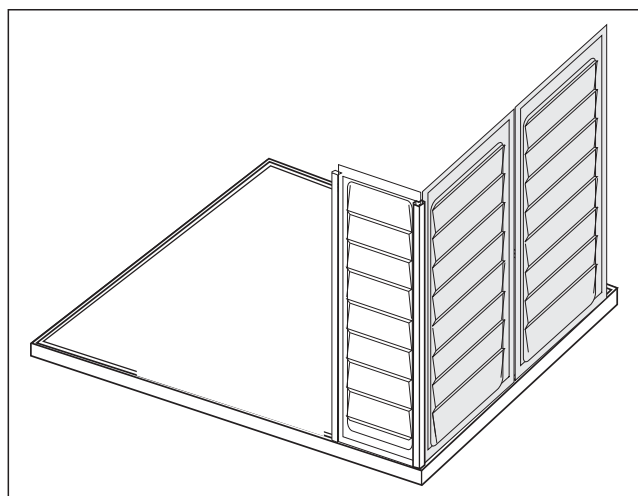
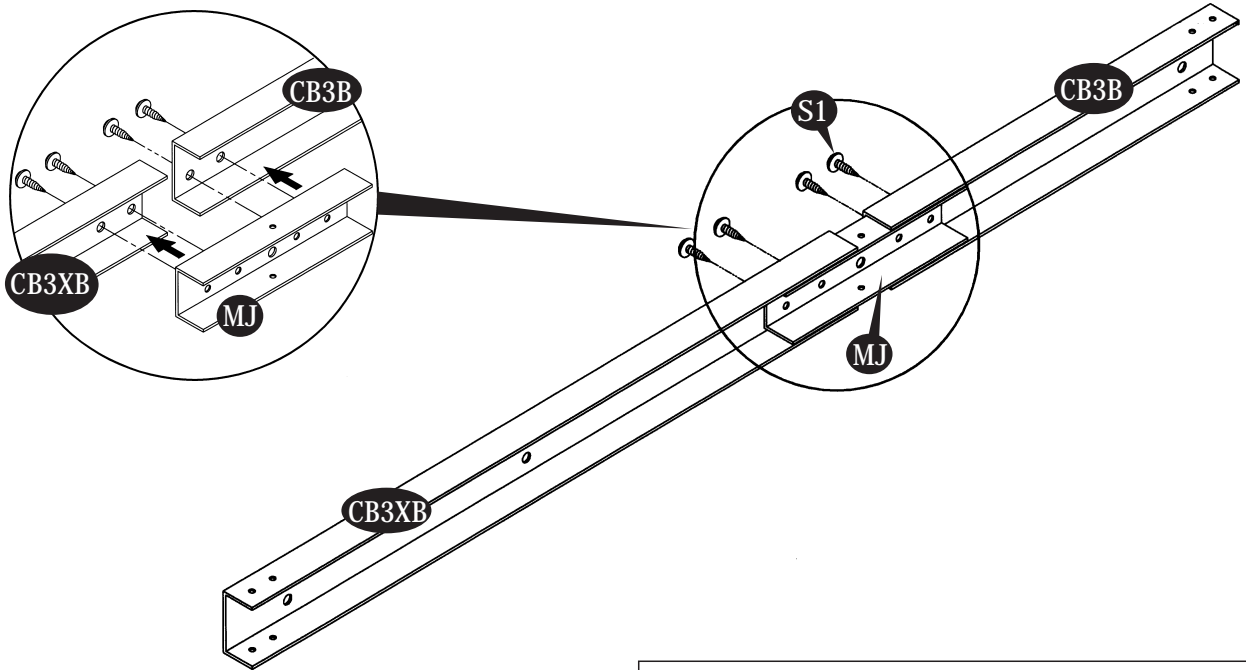

Fig.4: Use (S1) screws. Fix (CB2B) to (FCB).



9. Assemble back center bands (CB3B) and (CB3XB) with middle joining support (MJ). Use (S1) screws.



10. Continue connecting the back panels and columns in sequence along base (B22) and (B21). Fix columns to base with (S1) screws.

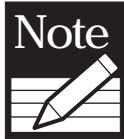

Note For installation of window follow the Window Kit Installation manual at this point.

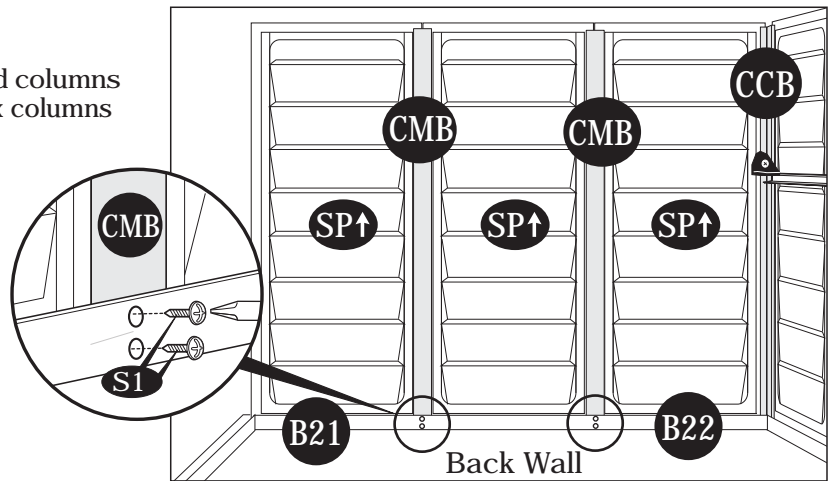

11. Fix the corner column (CCB) to last panel and base.

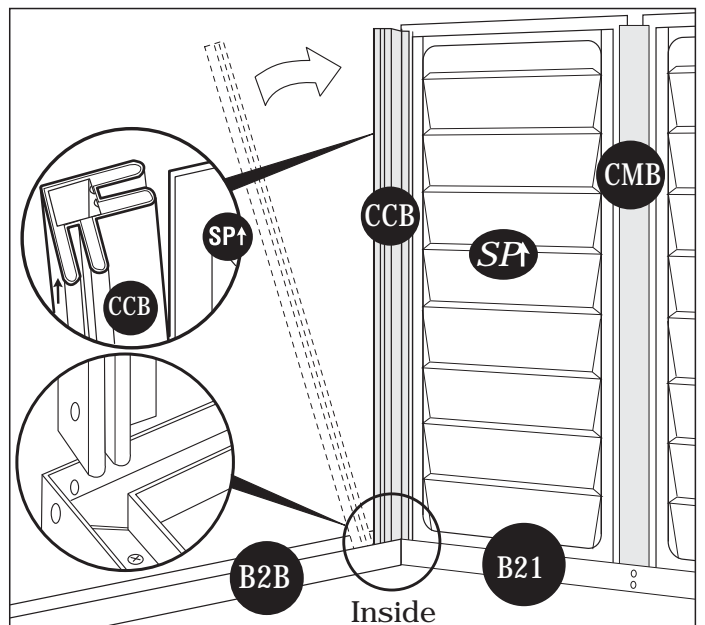

12. Working from outside, use (S1) screws to secure the corner column (CCB) to bases (B21) and (B2B)

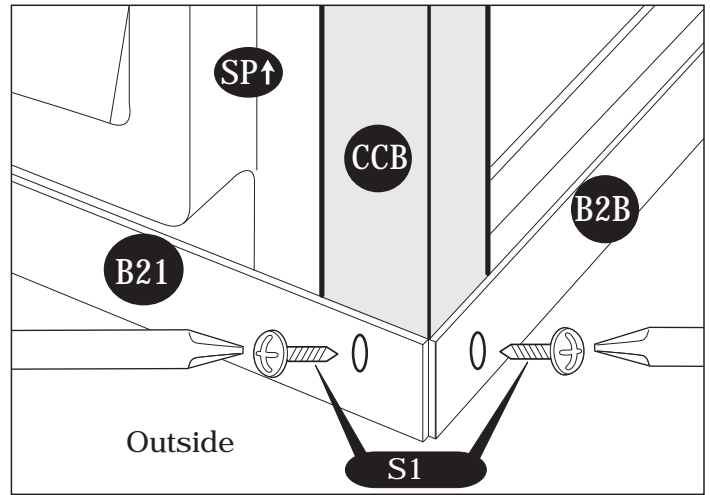

13. Stabilize side panels with center bands (CB3B & CB3XB). Fix the center band fitting (FCB) to corner column (CCB).
See figure 1. Follow figures 2, 3, 4, 5 and 6.

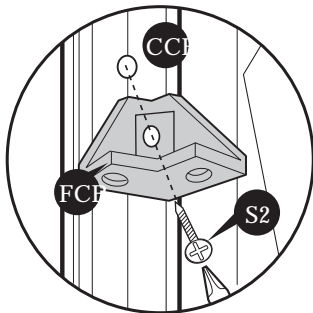
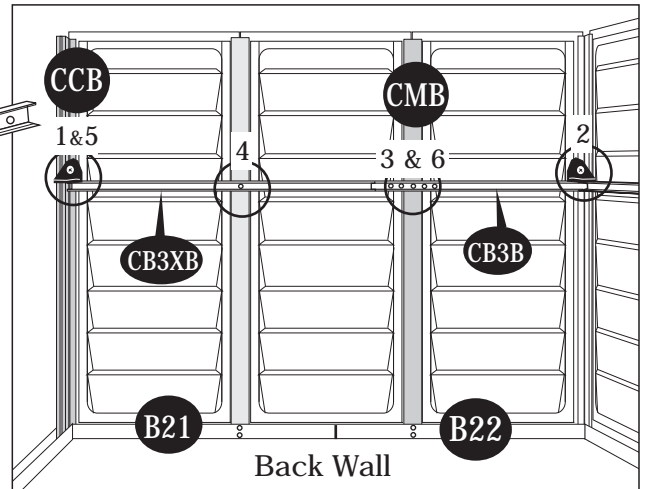
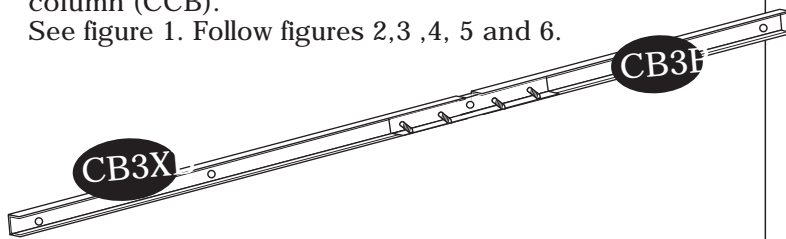

Fig.1: Use (S2) screws. Fix (FCB) to (CCB). Leave it loose.

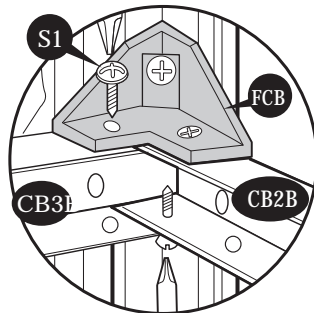

Fig. 2: Use (S1) screws. Fix (CB3B) to (FCB) and (CB2B).

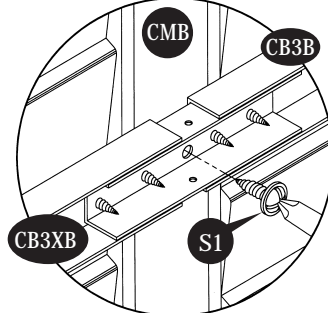

Fig.3: Fix to (CMB) with (S1) screw.

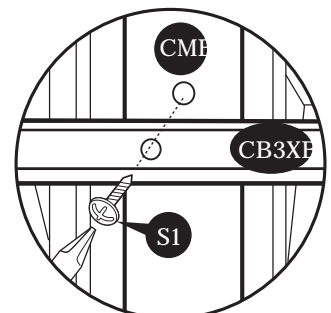

Fig.4: Fix to (CMB) with (S1) screws.

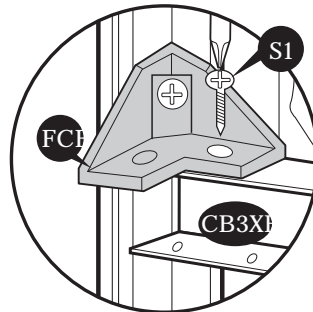

Fig.5: Use (S1) screws. Fix (CB3XB) to (FCB).

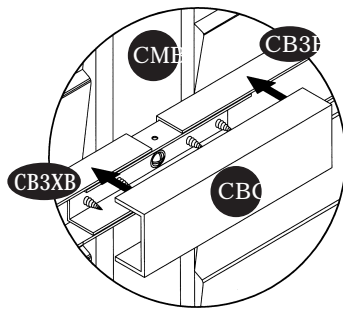
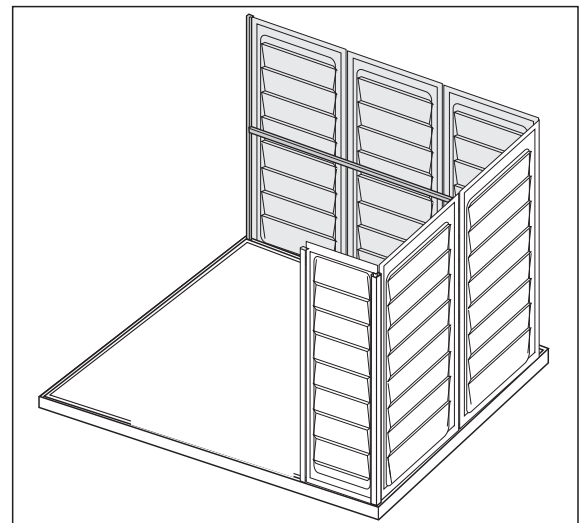
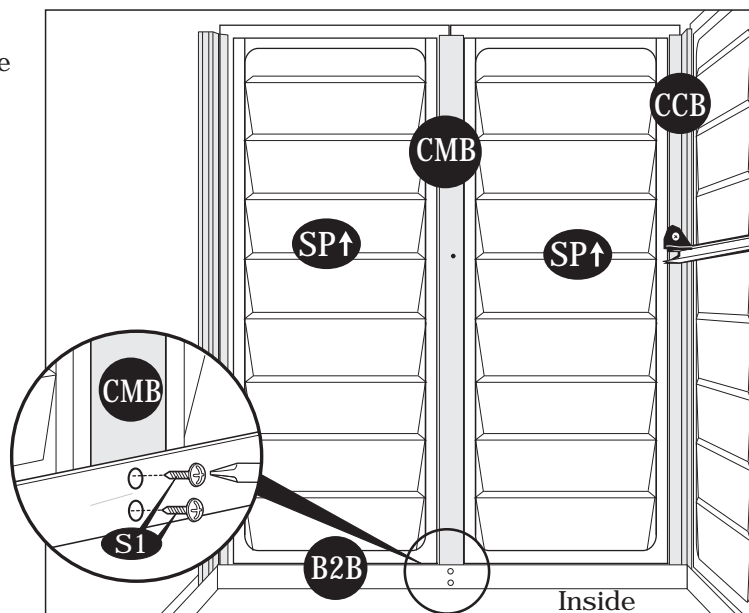

Fig.6: Center band joint must be cover with (CBC) cover to avoid the injury.



14. Working from inside continue connecting the 2 side panels (SP↑) and columns (CMB) in sequence along (B2B) base. Use (S1) screws to fix columns to base.



15. Slide corner column (CCB) into the side panel (SP↑) pushing the column into position.

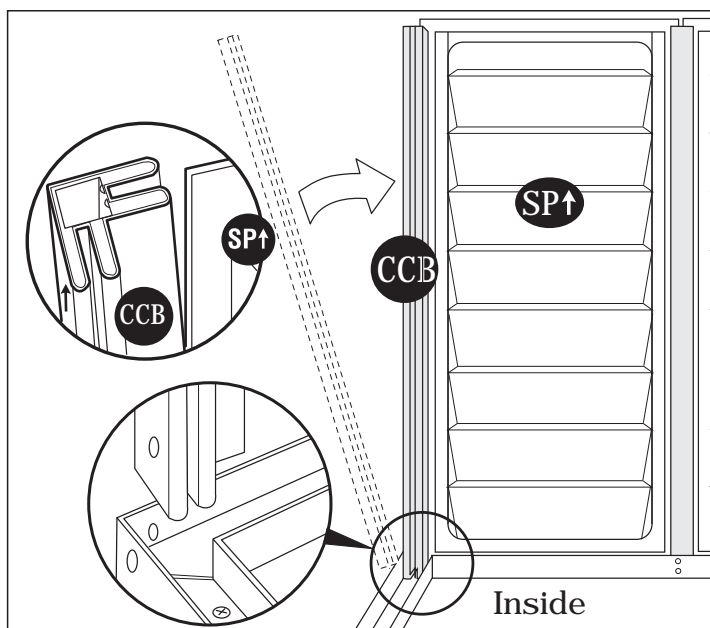

16. Working from outside use (S1) screws to secure the corner column (CCB) to bases (B2B) and (B1LB).

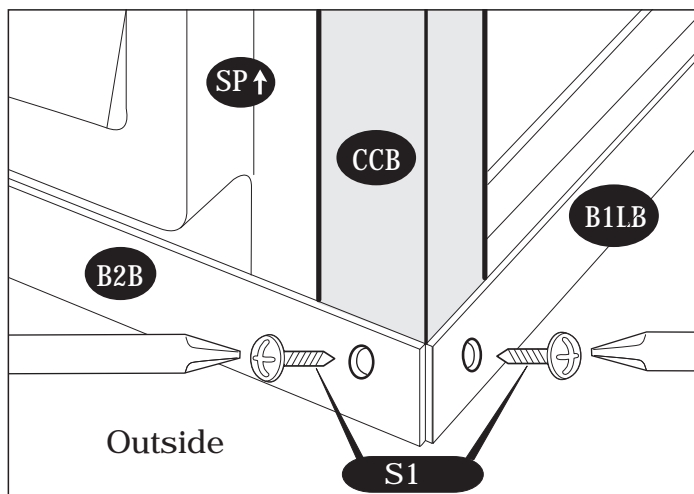

17. Stabilize the side panels with center band (CB2B). Fix (FCB) to column (CCB) See (fig.1) (fig.2) (fig.3) and (fig.4) for details.

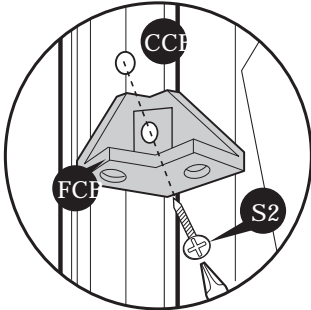
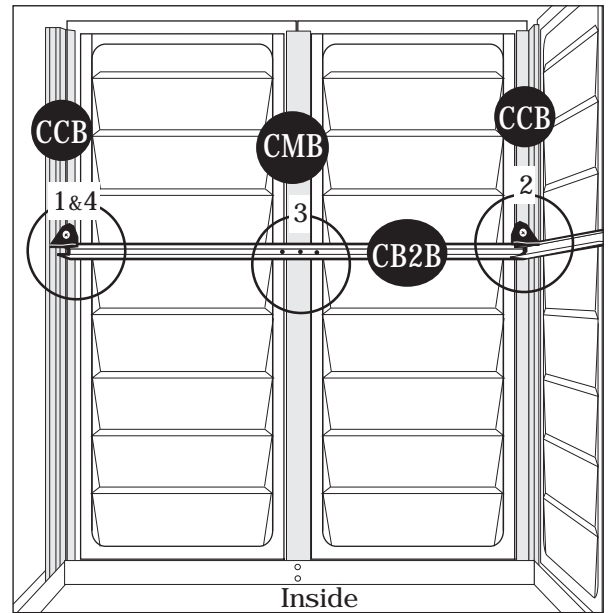

Fig.1: Use (S2) screw. Fix (FCB) to (CCB). Leave it loose.

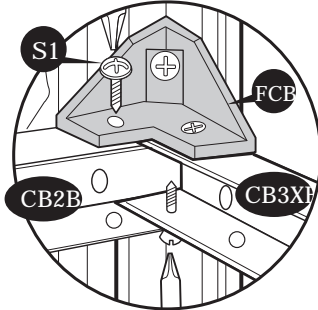

Fig.2: Use (S1) screws. Fix (CB2B) to (FCB) and (CB3XB).

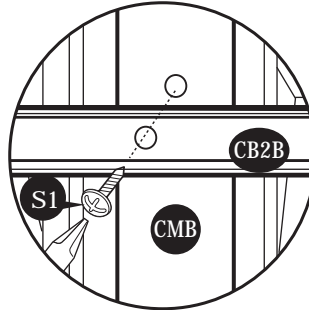

Fig.3: Use (S1) screws. Fix (CB2B) to (CMB) column.

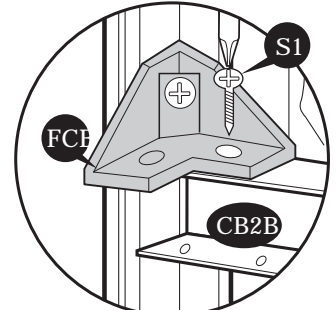
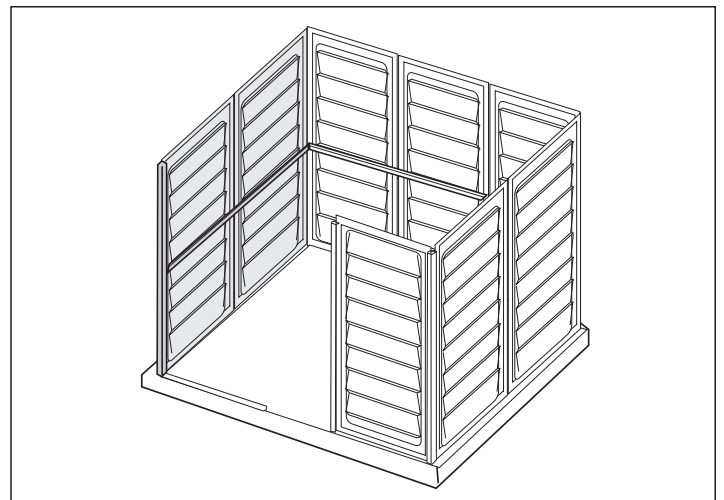
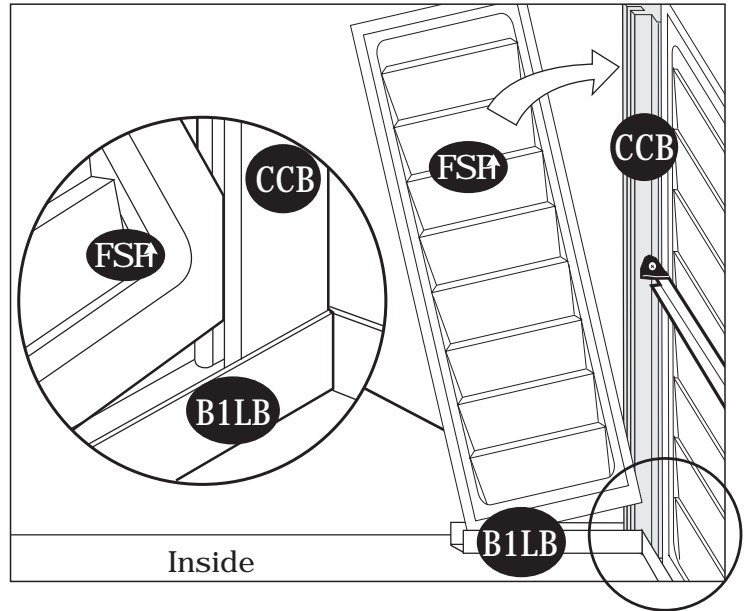

Fig.4: Use (S1) screw. Fix (CB2B) to (FCB).



18. Insert the side panel (FSP↑) into the groove of column (CCB). Start at the bottom with panel at an angle then push into place.



19. Slide door column (CDLB) into the U-Channel Base (B1LB) on the left side of the door. Line up the pre-drilled holes on (CDLB) Column with pre-drilled holes on U-Channel Base (B1LB). Secure with two (S1) screws from the inside. (see blowup detail).

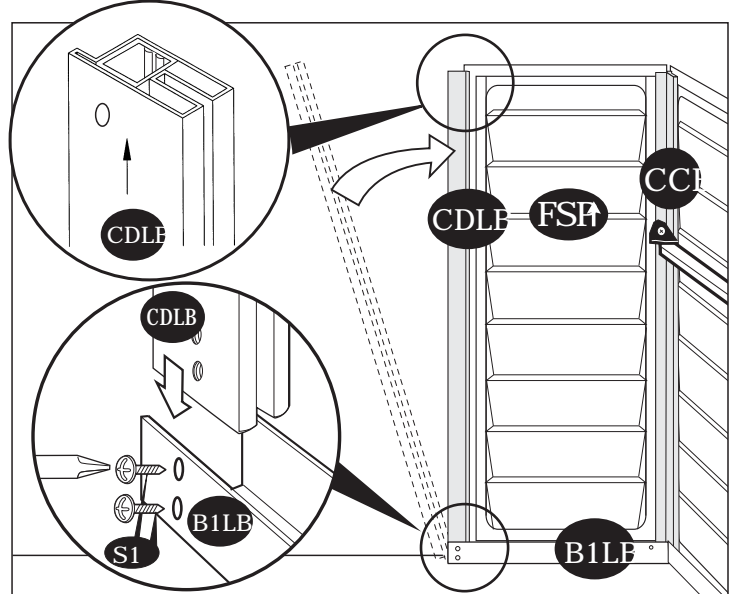

20. Attach the center band (CB1B) to door column, corner column and center band (CB2B). See figures 1 and 2.

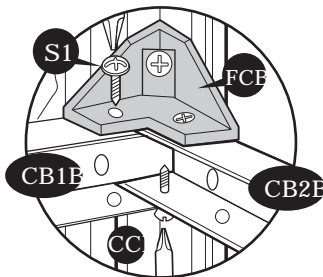

Fig.1: Use (S1) screws. Fix (CB1B) to (FCB) and (CB2B).

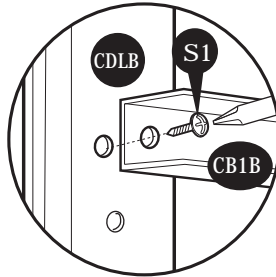
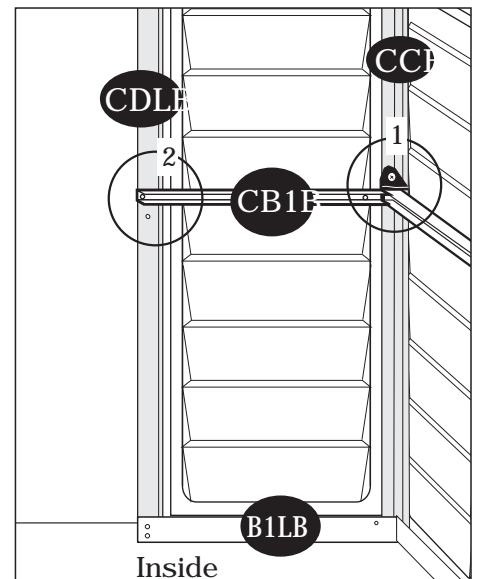

Fig.2: Use (S1) screw. Fix (CB1B) to (CDLB)



Note After completing the center band assembly, fully tighten the four center band fittings (FCB) to the corner column (CCB).

21. Fix center band (CB4B) to (CDLB) and base (B1LB).
See Fig. 1, 2 and 3.

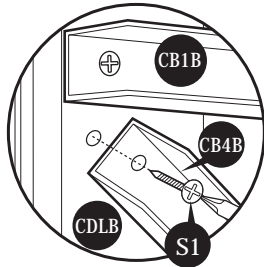

Fig. 1: Use (S1) screw. Fix (CB4B) to (CDLB)

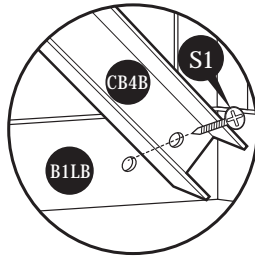

Fig. 2: Use (S1) screw. Fix (CB4B) to base (B1LB)

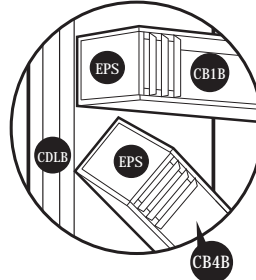
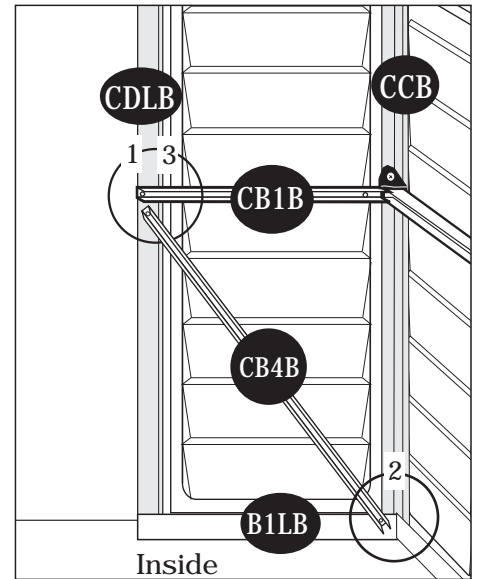
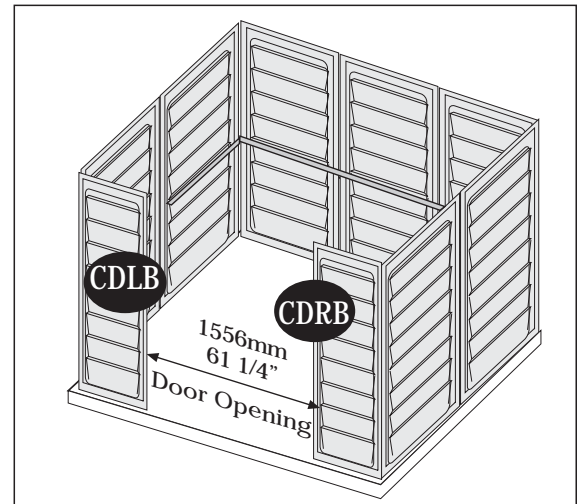

Fig. 3: Fix the (EPS) at the end of (CB1B) & (CB4B).



22. Make sure the door opening between the door columns (CDLB) and (CDRB) is 61 1/4" (1556mm). This will ensure a perfect fit for the doors.



C. Roof Frame



Parts Needed:

(4) RS1 Roof Structure	(RS1XB)	(1) RS11 Roof Structure Support Short	(RS11B)
(4) RS2 Roof Structure	(RS2B)	(1) RS12 Roof Structure Support Long	(RS12B)
(2) RS3 Roof Structure	(RS3B)	(1) Door Stopper Horizontal	(DSH)
(2) RS4 Roof Structure	(RS4XB)	(1) Door Column Fitting Left	(FDCL)
(4) RS5 Roof Structure	(RS5B)	(1) Door Column Fitting Right	(FDCR)
(4) RS8 Roof Structure Support	(RS8B)	(4) Corner Column Fitting	(FCC)
(4) RS9 Roof Structure Support Short	(RS9B)	(4) Middle Column Fitting	(FMC)
(2) Middle Joining Support	(MJ)	(4) 90 Degree Joint	(RJ)
(2) RS10 Roof Structure Support	(RS10B)		

1. Insert the middle column fitting (FMC) into top of the middle columns (CMB). Fix the column to fittings with (S1) screws from inside the shed.

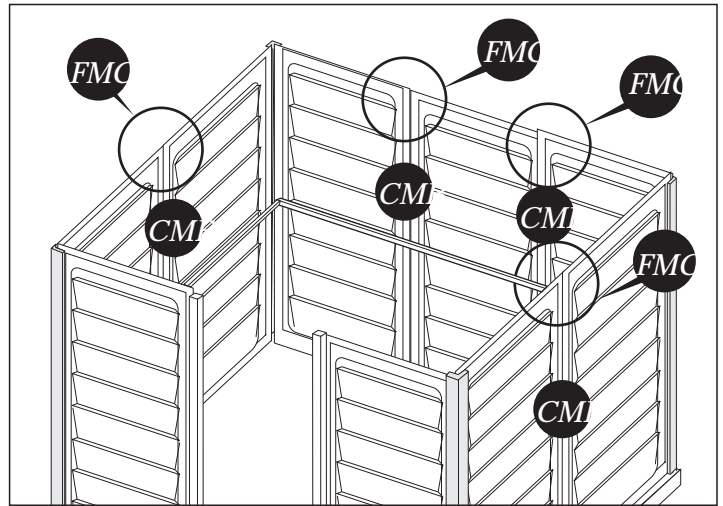
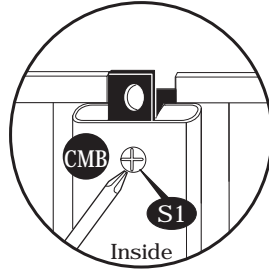
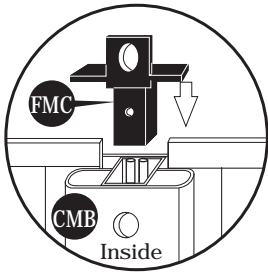

2. Insert the corner column fittings (FCC) into the corner columns (CCB). Fix with (S1) screws from outside of the shed.

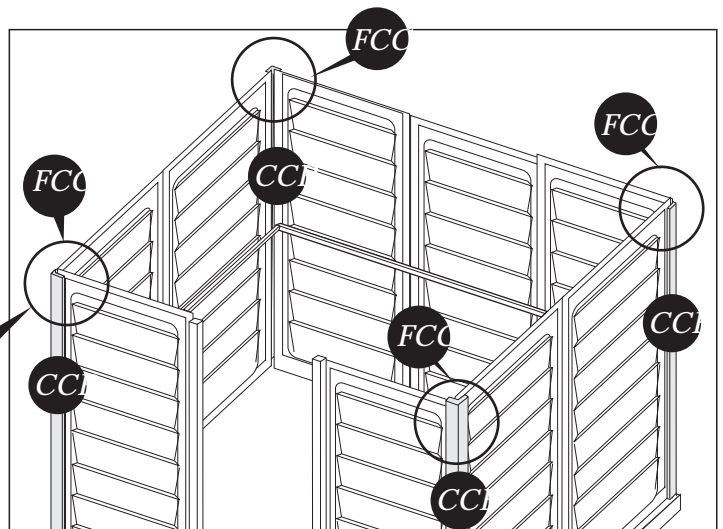
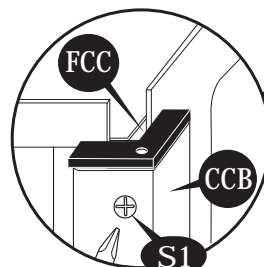
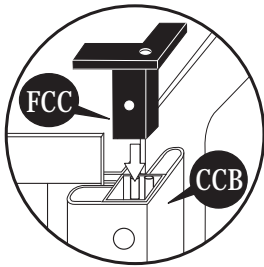

3. Insert the door column fittings (FDCL) and (FDCR) left and right into the door columns (CDLB) and (CDRB). Fix with (S1) screws from inside the shed.

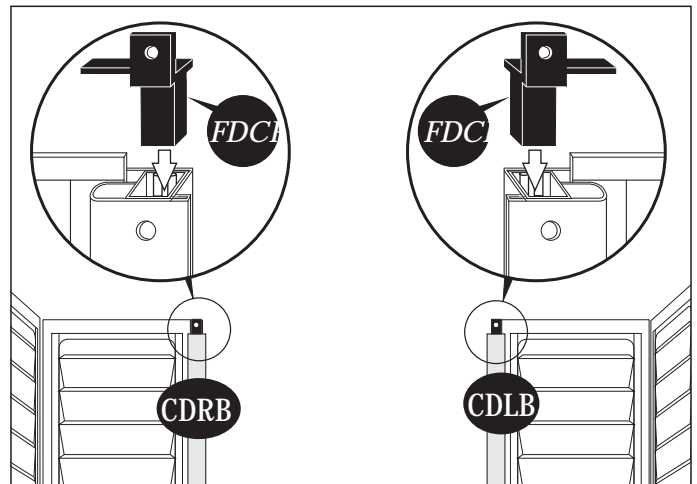
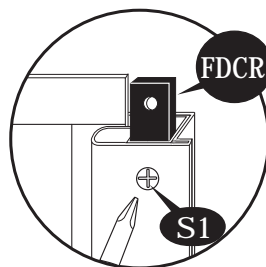

ROOF STRUCTURE EXPLODED VIEW

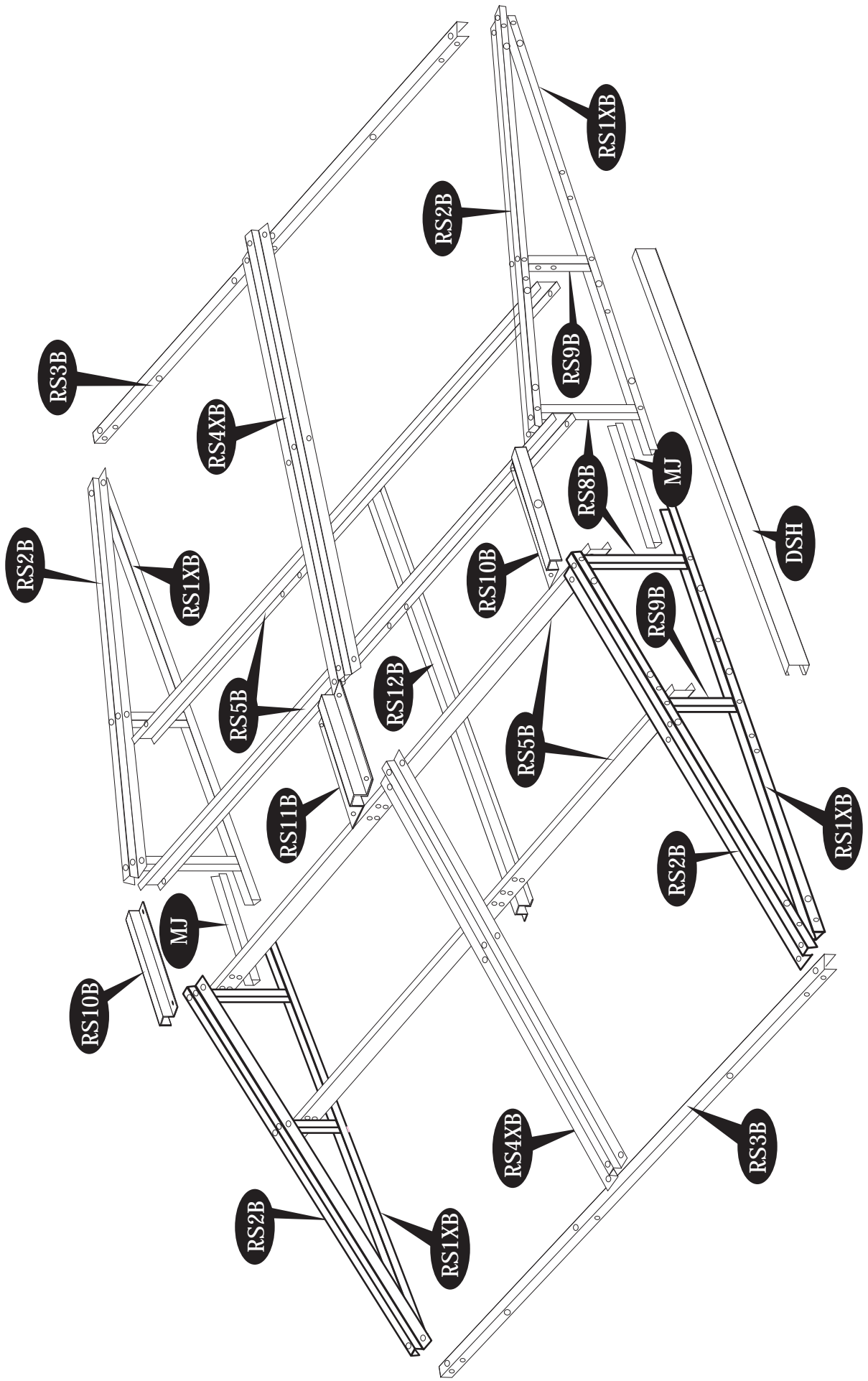

Front roof structure assembly

4. Assemble front roof structures (RS1XB) 2nos. and middle joining support (MJ) together with 4 (S1) screws as shown in fig.

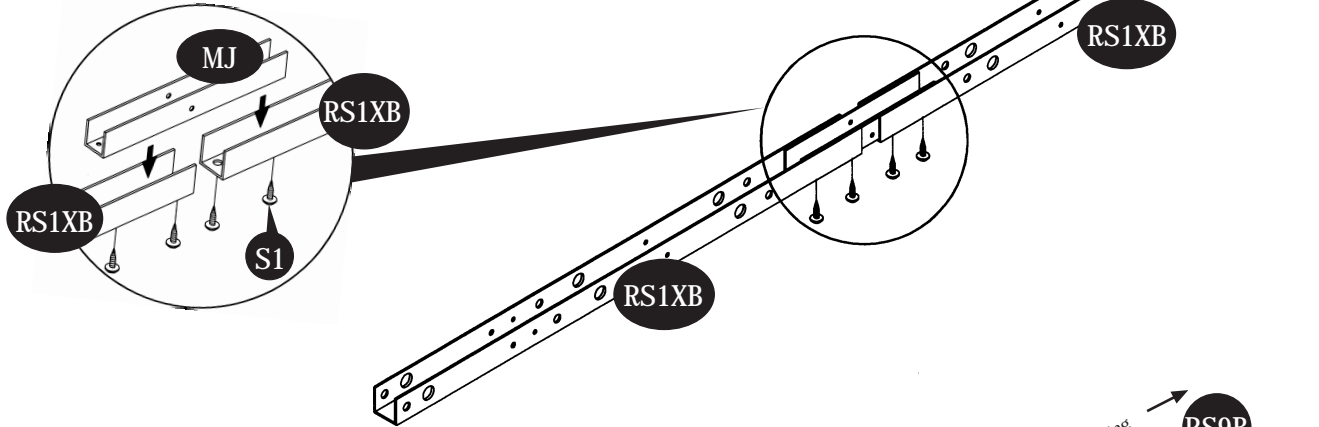

5. Assemble roof structure support (RS8B) and (RS9B) to (RS1XB) assembly with only 4 (S1) screws.

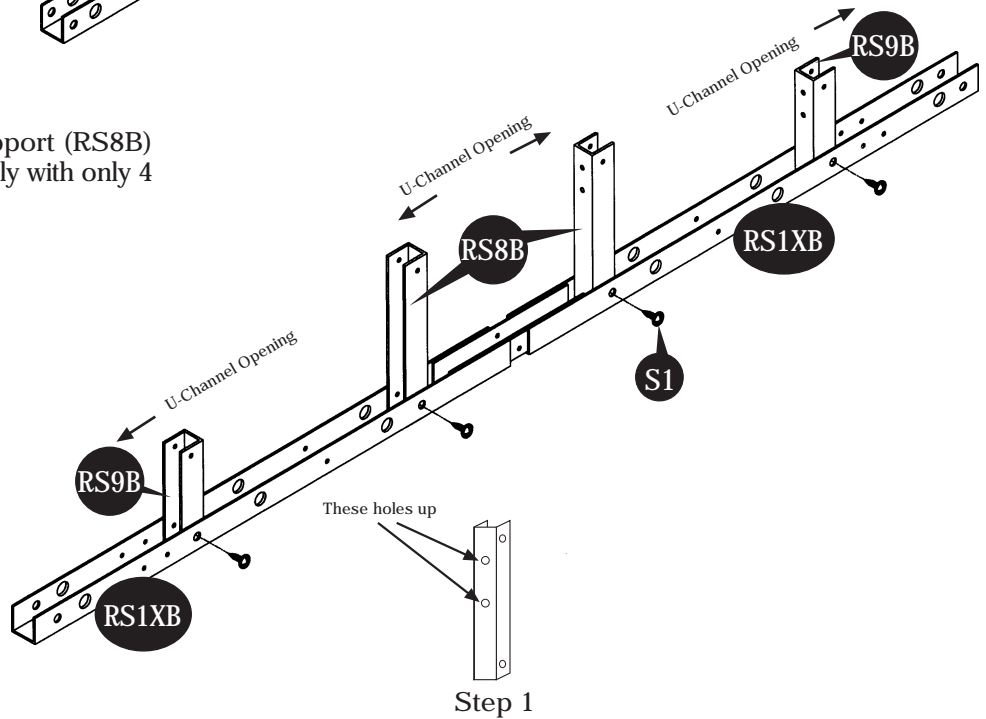

6. Assemble roof structure (RS2B) to (RS8B) and (RS9B) with 8 (S1) screws.

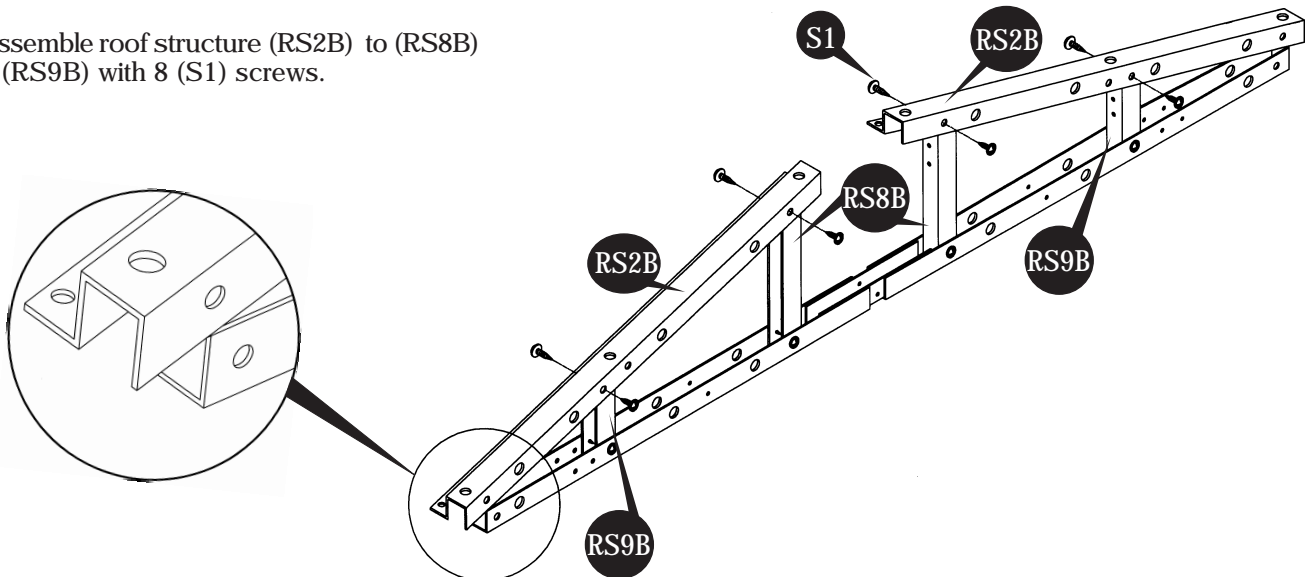

Back roof structure assembly

7. Assemble back roof structures (RS1XB) 2 nos. and middle joining support (MJ) together with 4 (S1) screws.

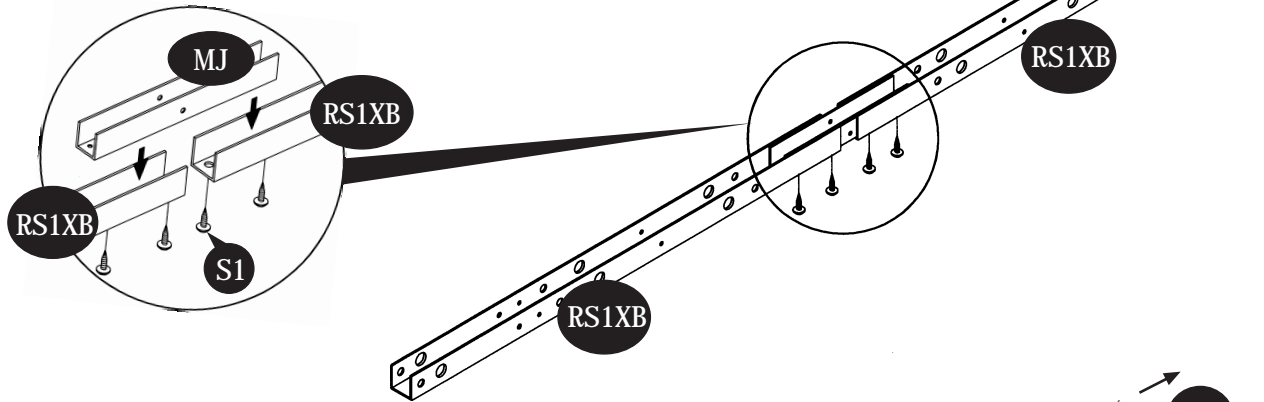

8. Assemble roof structure support (RS8B) and (RS9B) to (RS1XB) assembly with 8 (S1) screws.

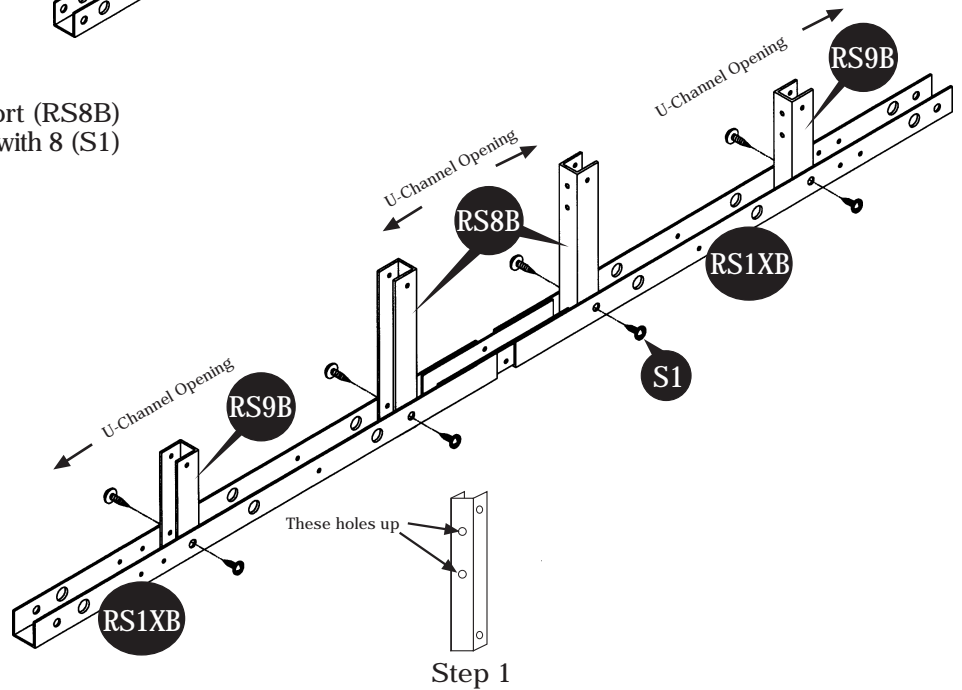

9. Assemble roof structure (RS2B) to (RS8B) and (RS9B) with 8 (S1) screws.

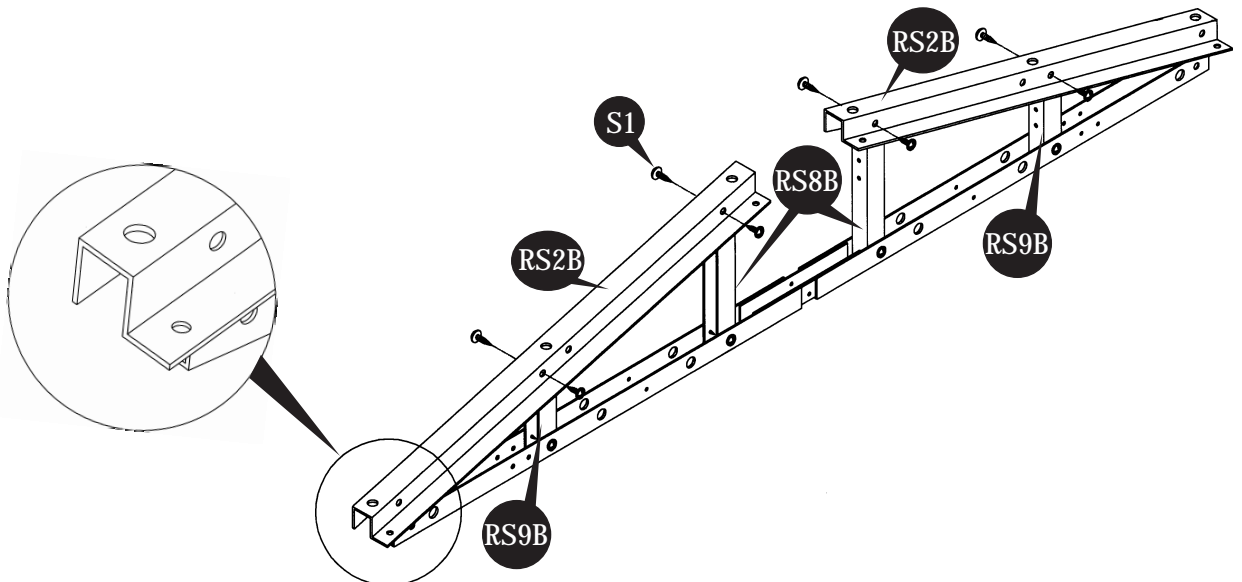

10. Place the assembled front roof structure into position on top of door columns. Line up pre-drilled holes with door column fittings (FDCL) & (FDCR). Use (S1) screws to fix front roof structure to the door columns with left and right door fittings.

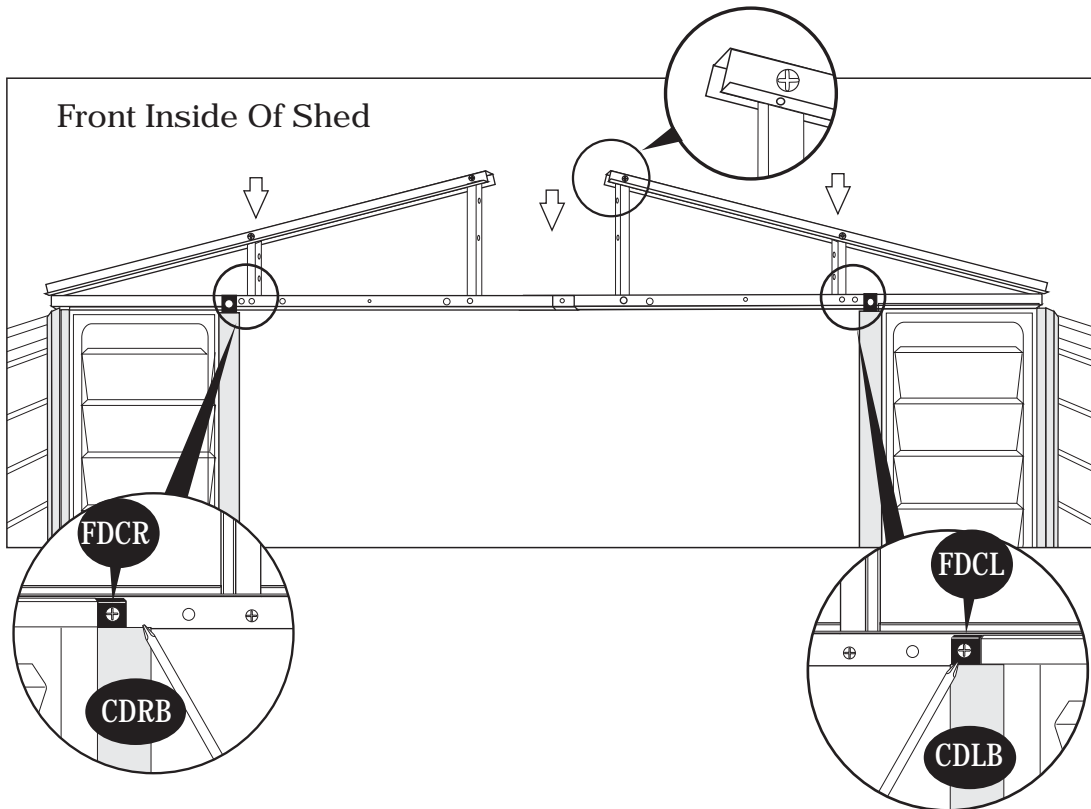

11. Fix the door stopper horizontal (DSH) to the front roof structure from inside with 8 (S1) screws. Position the latch hole to face down.

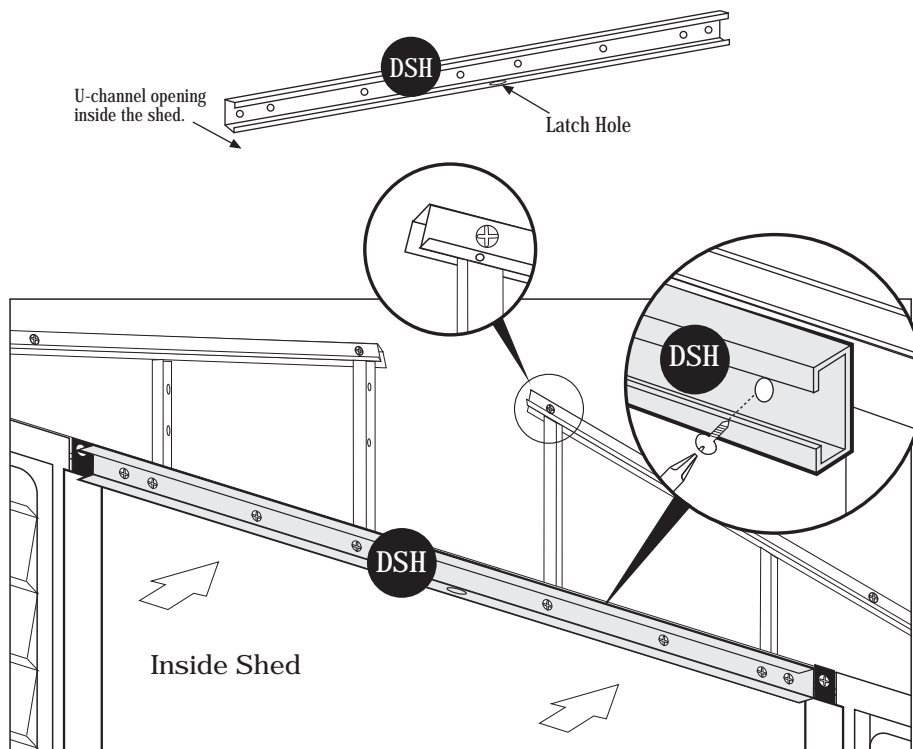

12. Place the assembled back roof structure into position on top of columns (CMB). Line up pre-drilled holes with column fittings (FMC). Use (S1) screws to fix back roof structure to (FMC).

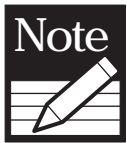
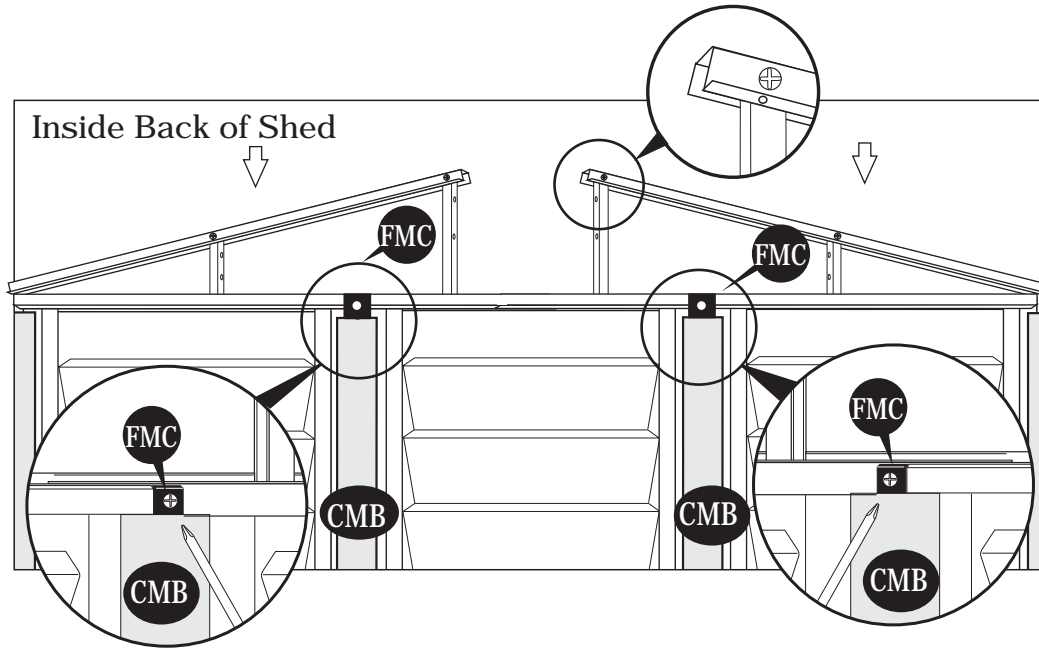

Note Make sure front and back assembly, the (RS2B) roof structure position towards inside the shed as shown in Fig.1 & Fig.2

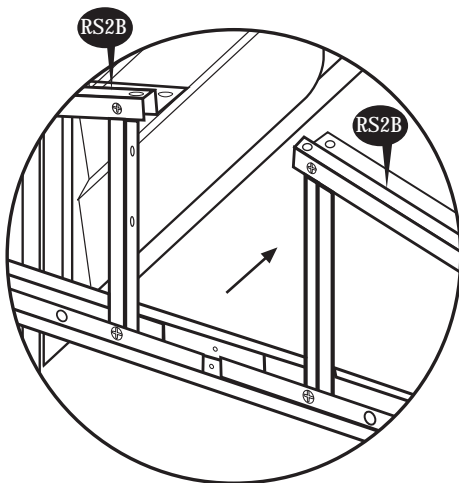
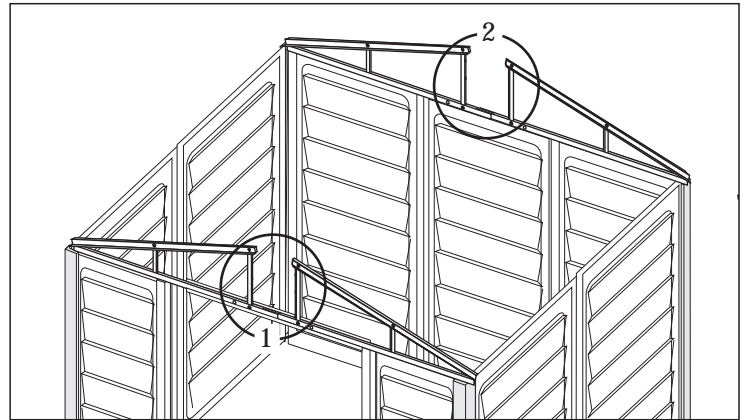

Fig.1

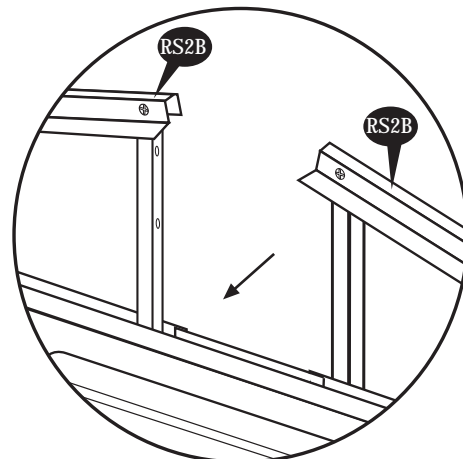
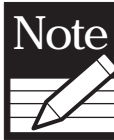
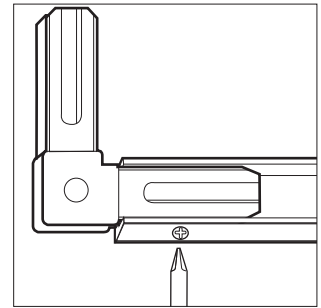
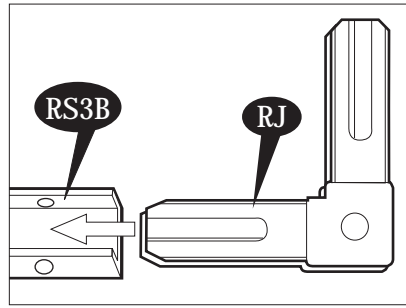
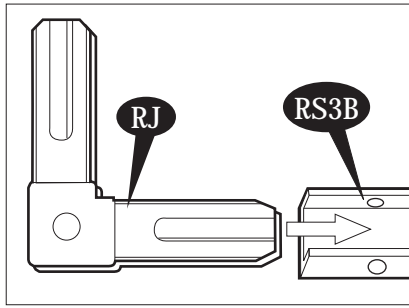
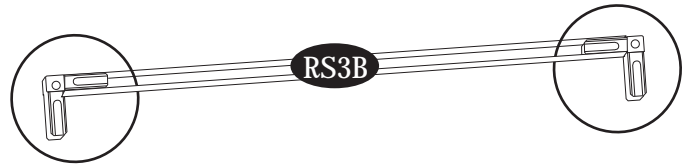
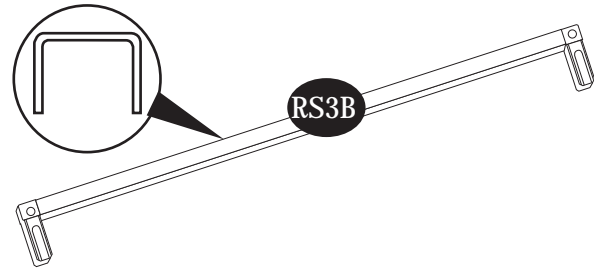

Fig.2

13. Insert 90 degree joint (RJ) into the (RS3B) U-channel Roof support. Use a hammer to push in. Repeat on both ends of (RS3B). Fix (RJ) to (RS3B) with (S1) screws (2 sets).



After assembly make sure (RS3B) roof structure's U-Channel is positioned down.



14. Insert the 90 degree joint (RJ) (assembled with roof structure RS3B) into the roof structures (RS1XB) . See (fig.1) Follow Fig. 2 and 3.

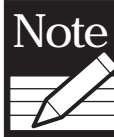

Notice the U-channel up position on roof structures (RS1XB).

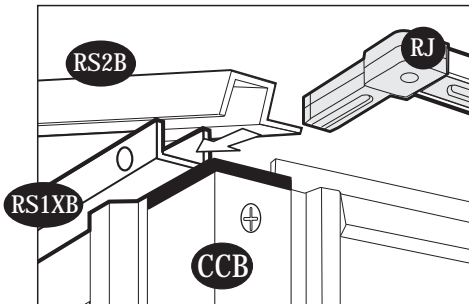
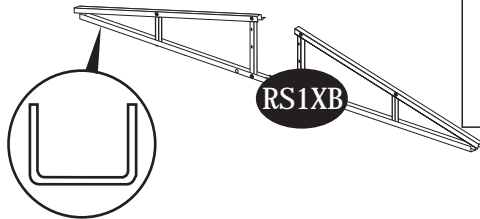
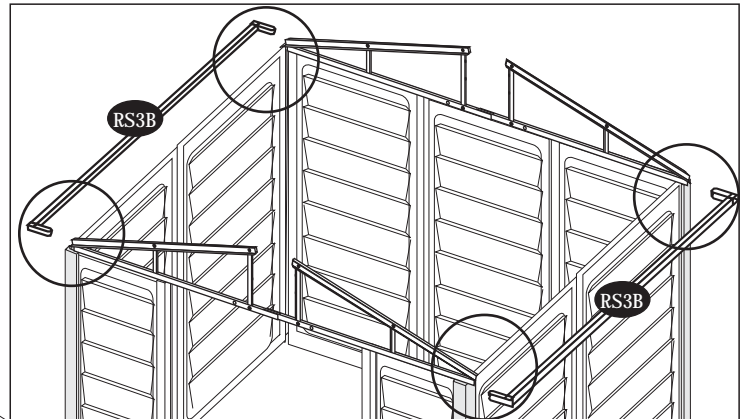

Fig.1

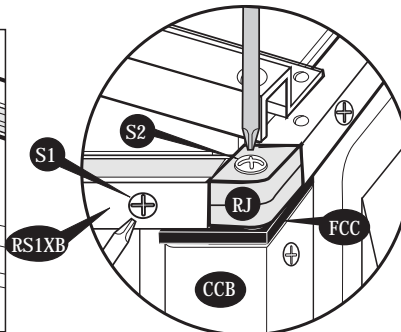

Fig.2

Secure (RJ) 90 degree joint to (RS1XB) with (S1) screws on top of the four corner columns (CCB).
Secure (RJ) with (FCC) using (S2) screw on all the four corner columns.

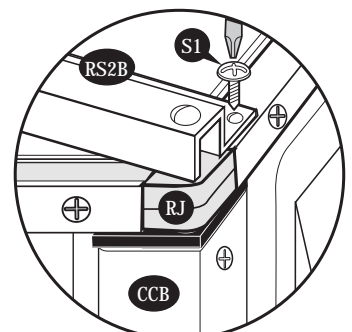
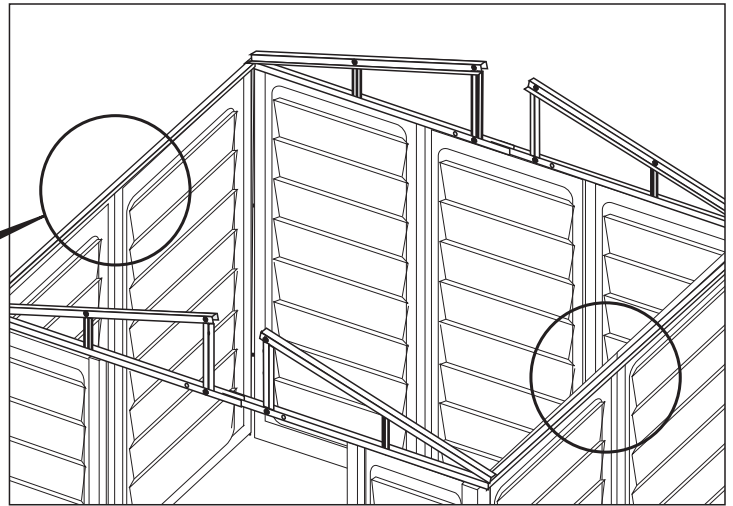
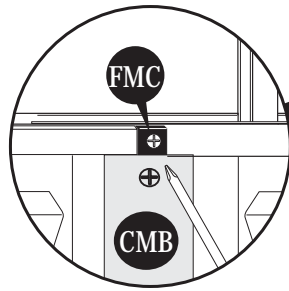

Fig.3

Fix (RS2B) to 90 degree joint (RJ) through (RS3B) with (S1) screw.

15. Fix the (RS3B) to middle column fitting (FMC) with (S1) screws.



16. Place the roof structure (RS5B) into position on roof structure supports (RS8B).
Use (S1) screws to fix (RS5B) to (RS8B).
See (fig.1) and (fig. 2).

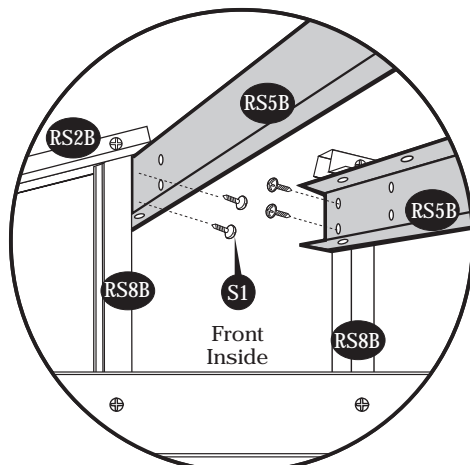
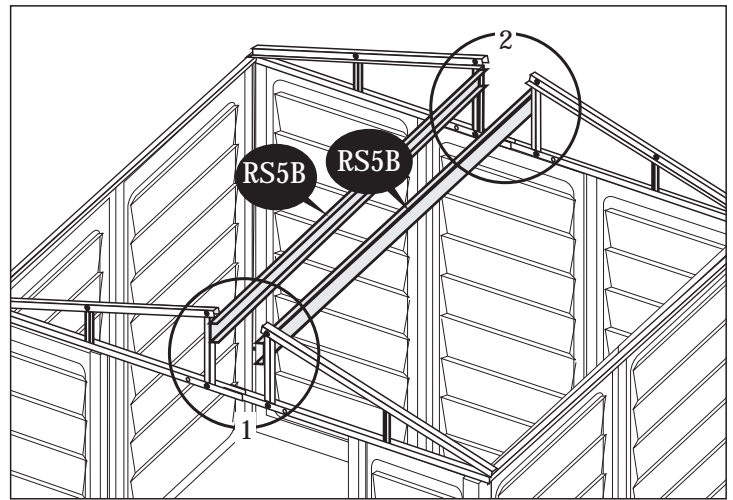
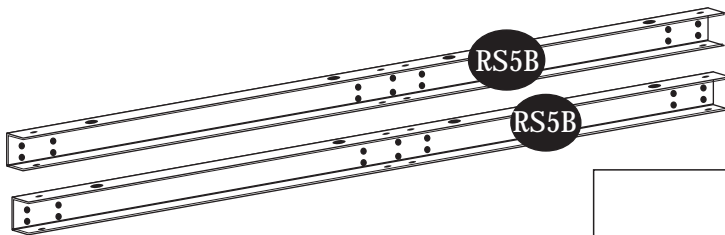

fig.1

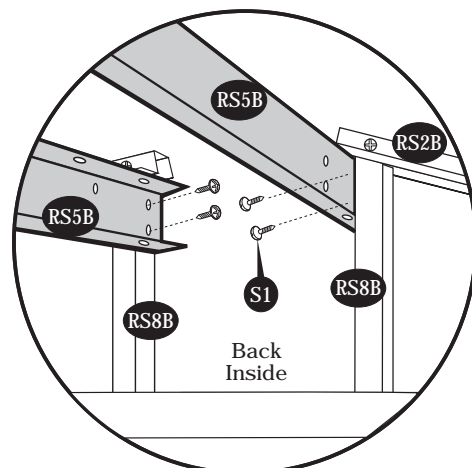

fig.2

17. Attach the roof structures (RS5B) to (RS9B) with (S1) screws. See fig.1, 2, 3 and 4.

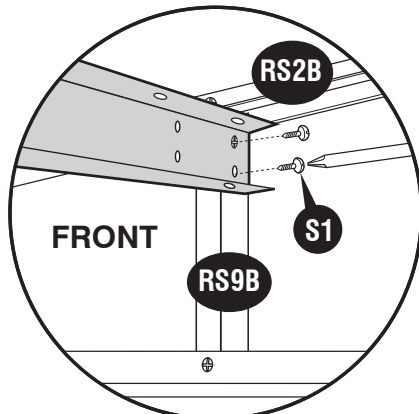
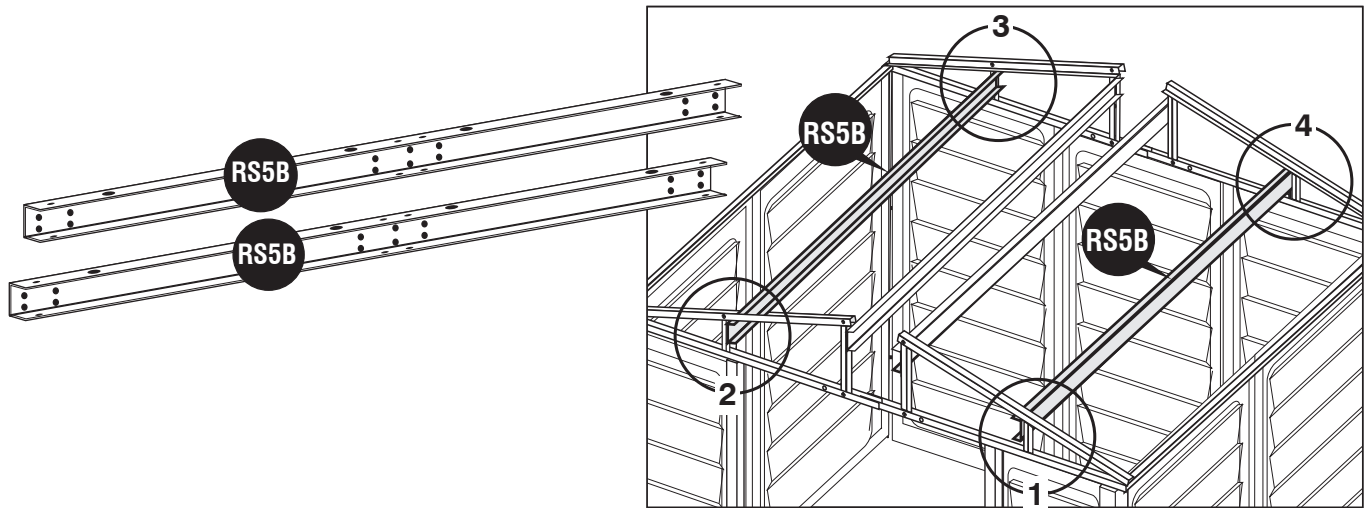

fig.1

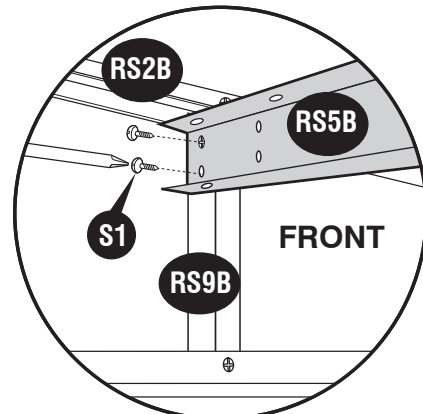

fig.2

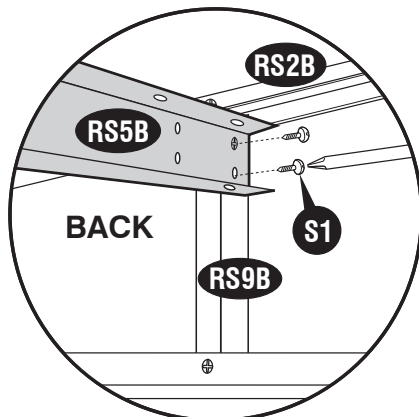

fig.3

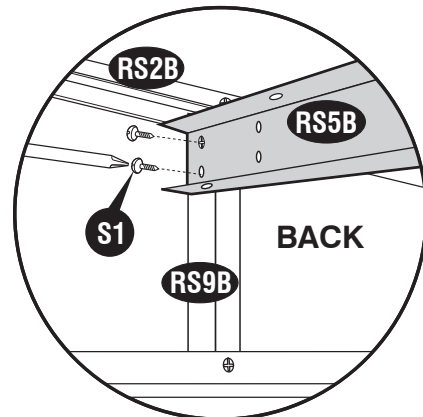

fig.4

18. Attach the roof structures (RS4XB) to (RS3B) with (S1) screws. See fig.1 & 3.

18a. Attach the roof structures (RS4XB) to (RS5B) with (S7) screws. See fig.2 & 4.

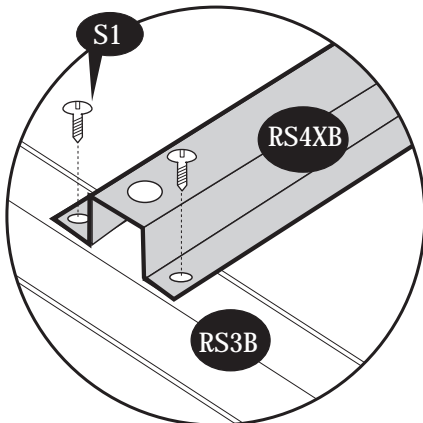
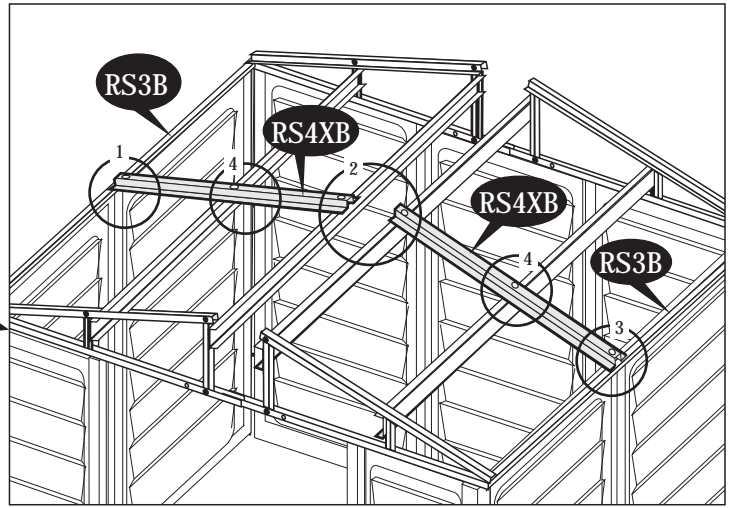
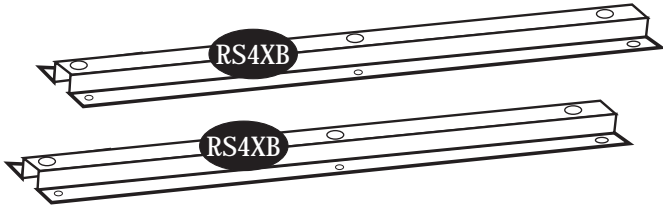

fig.1

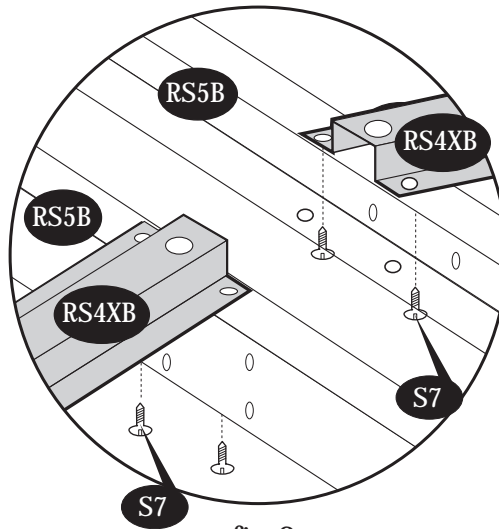

fig.2

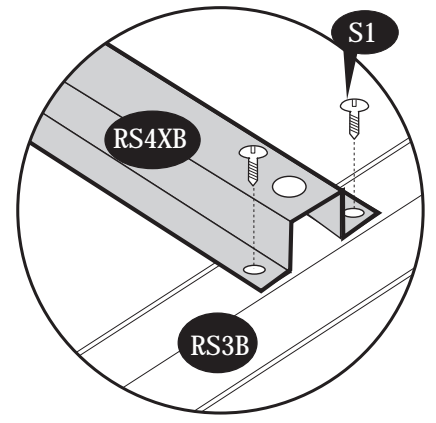

fig.3

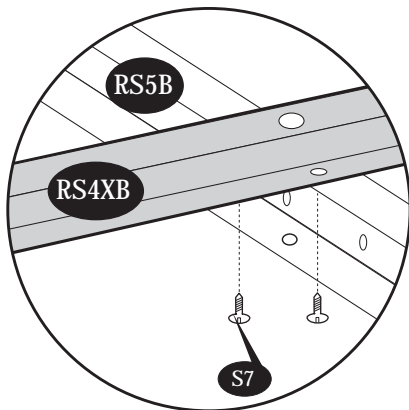
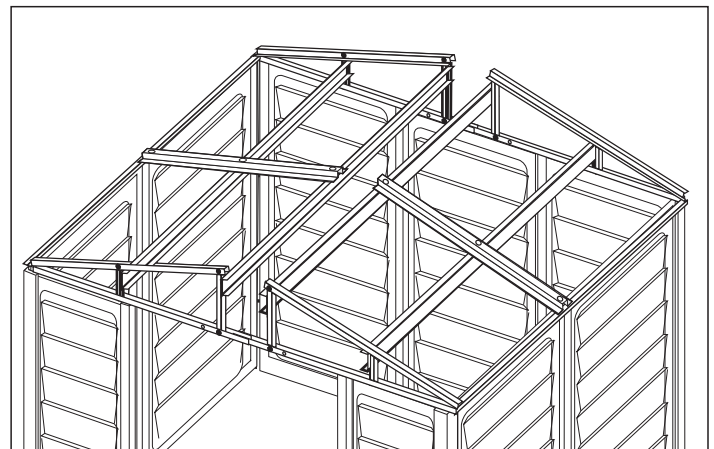
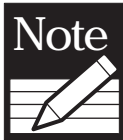
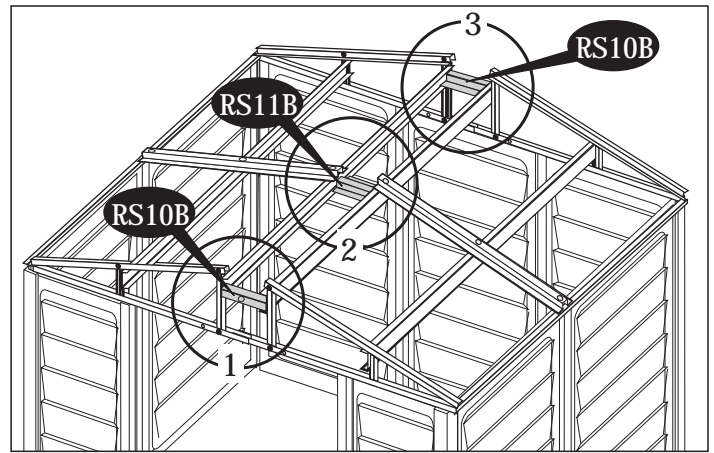
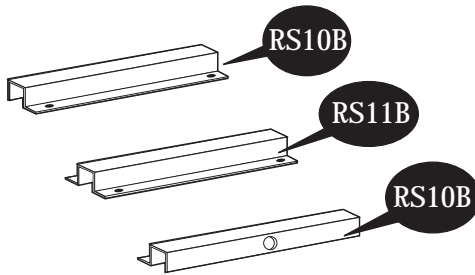

fig.4



19. Attach roof structure support (RS10B) and (RS11B) to roof structures (RS5B) using (S1) screws. See (fig.1), (fig.2) and (fig.3).



Note Make sure the hole in (RS10B) face outward on both sides.

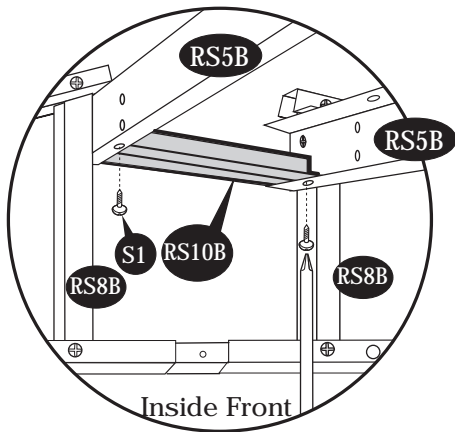
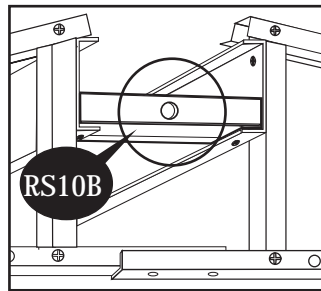

fig.1

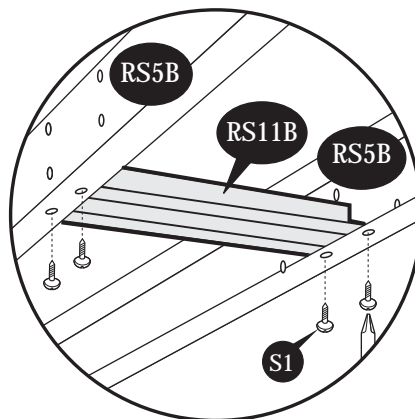

fig.2

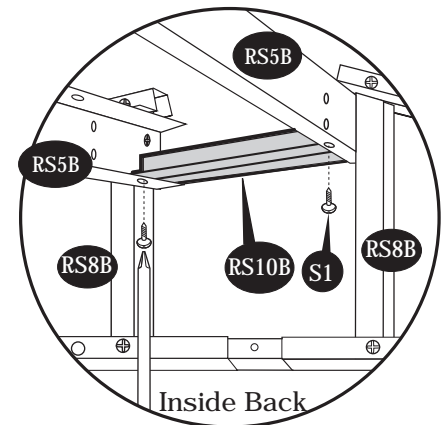

fig.3

20. Attach the roof structures support (RS12B) with (RS5A) and (RS5A) with (S1) screws. See fig.1 and 2.

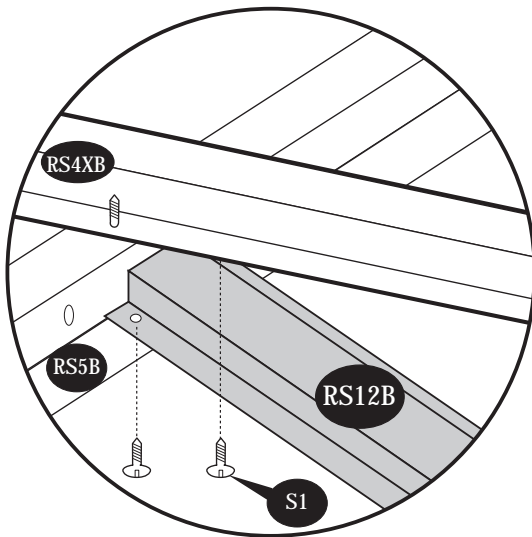
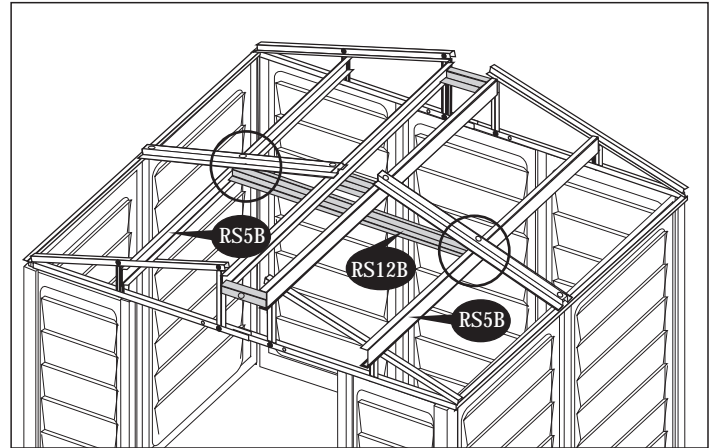
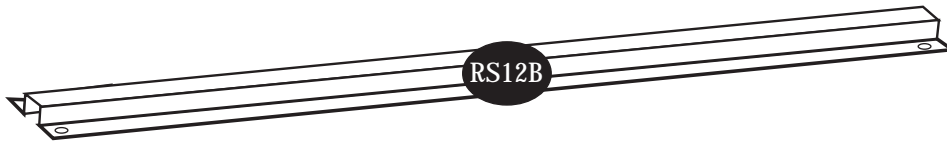

fig.1

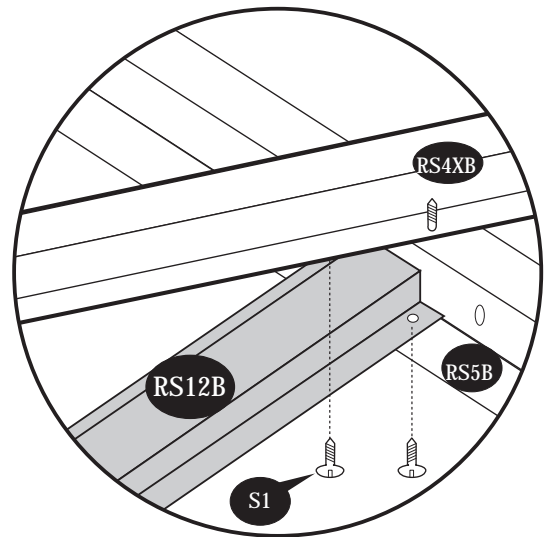
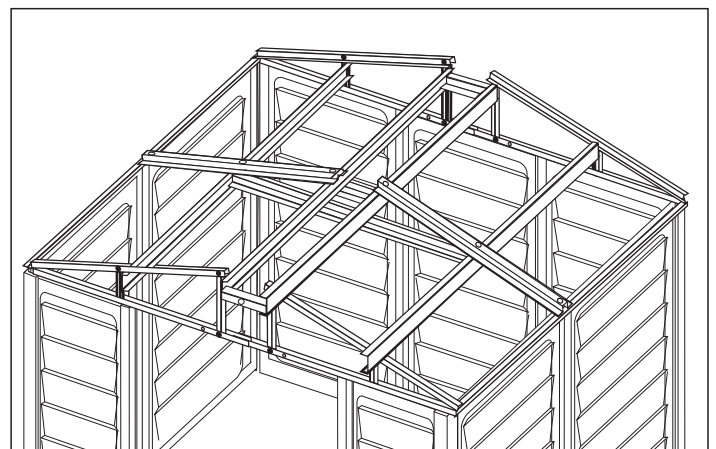

fig.2



D. Roof panels

Parts Needed:

(4) Roof Panels	(RP↑)
(2) Facia Panel Left	(FPLB)
(2) Facia Panel Right	(FPRB)
(2) Ridge Cover	(RRS)
(64) Roof Plugs w/Washer	(PPG)
(64) Roof Pins	(PIN)
(8) Sagging Support	(RS14B)

1. Place facia panel (FPRB) to front roof structure right side.

2. Line up the holes with roof structure and fix the roof plugs w/washers. Use a hammer to drive in plastic pins (rubber mallet). See figures 1, 2 & 3 for details. Place facia panel left (FPLB) to the front roof structure left side. Make sure (FPLB) overlaps on (FPRB). Repeat action to fix facia panels on backside. See Fig. 4, 5 & 6.

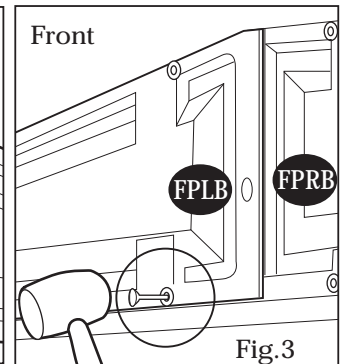
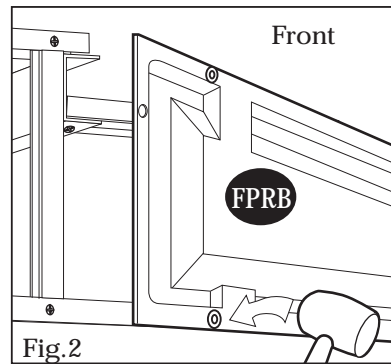
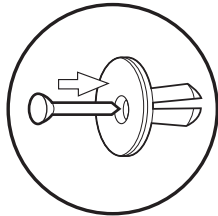
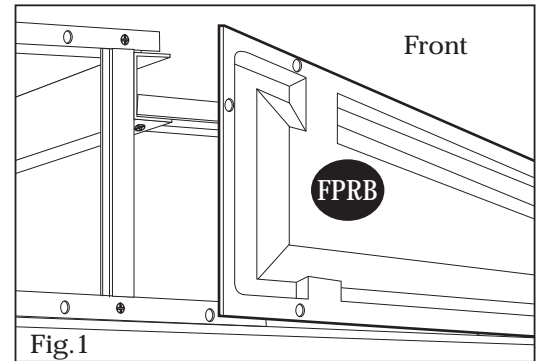

TIP First insert all roof plugs with washers to the panels (left & right) then drive in the roof pins.

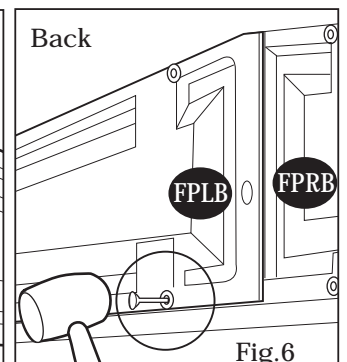
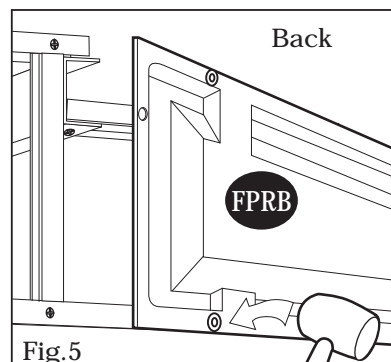
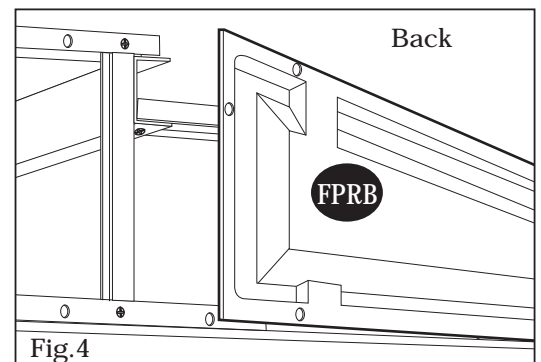

3. Start attaching the roof panels from (FPLB) corner side by sliding the roof panel (RP↑) on roof structure. Locate the hole positions of the roof panel and roof structure. Fix with plastic washers and plugs. Use a hammer to drive in plastic pins. See figures 1 thru 4.
Attaching the ridge cover (RRS) on top of the roof panels (RP↑), start from the front side of the shed.

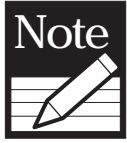

Use a screw driver to align the holes.

Insert roof plugs into roof panels only as indicated.

KEY
P Roof Plug

Note Leave holes unplugged at this point.

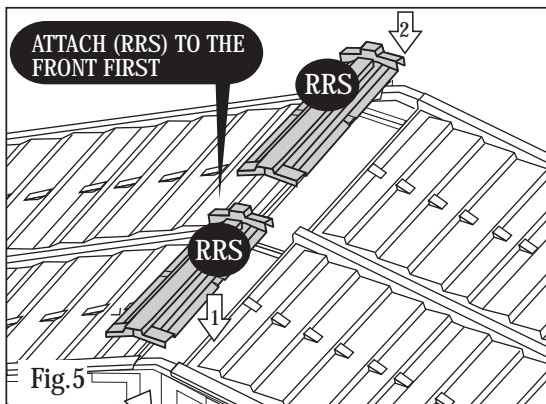
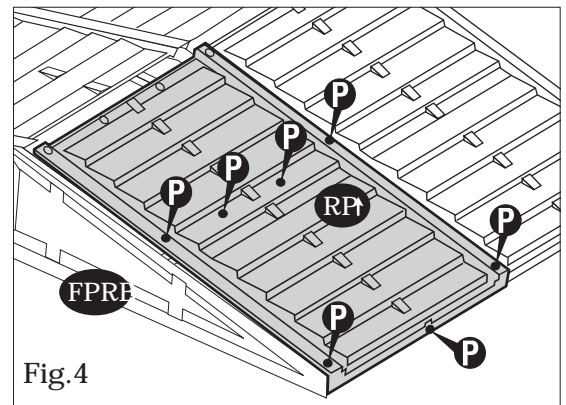
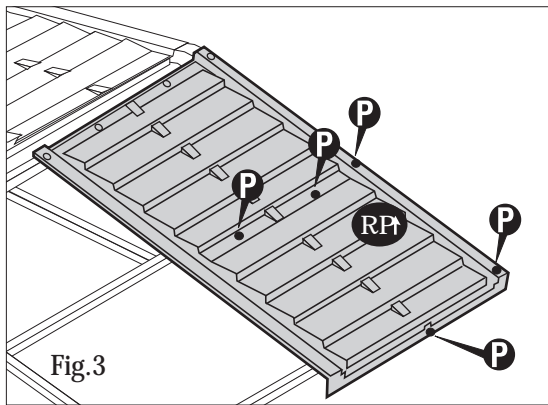
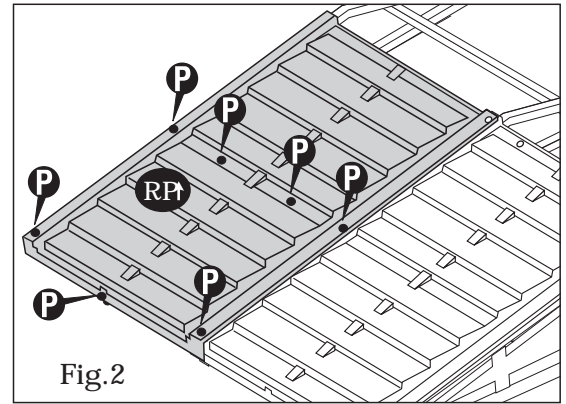
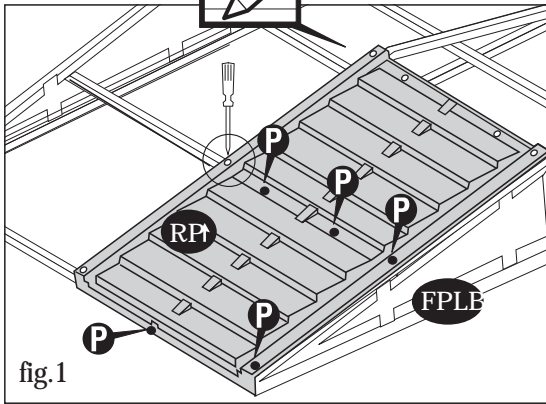

Front of Shed

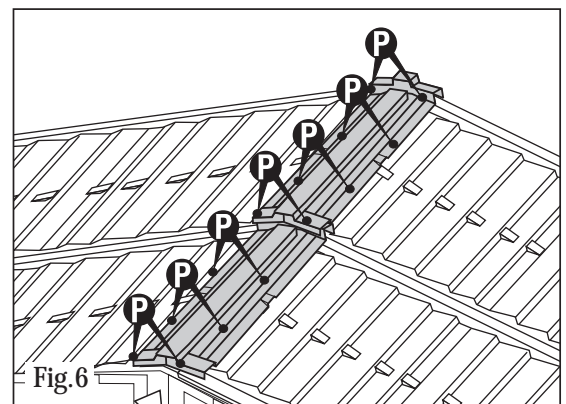

Front of Shed

4. Insert the sagging support (RS14B) from inside the shed by sliding in between roof structure (RS5) and roof panel until it reaches (RS3) roof structure for each panel. See figures.

5. Insert the sagging support (RS14B) from inside the shed by sliding in between roof structure (RS5) and roof panel until it touches the other roof structure (RS5). See figures.

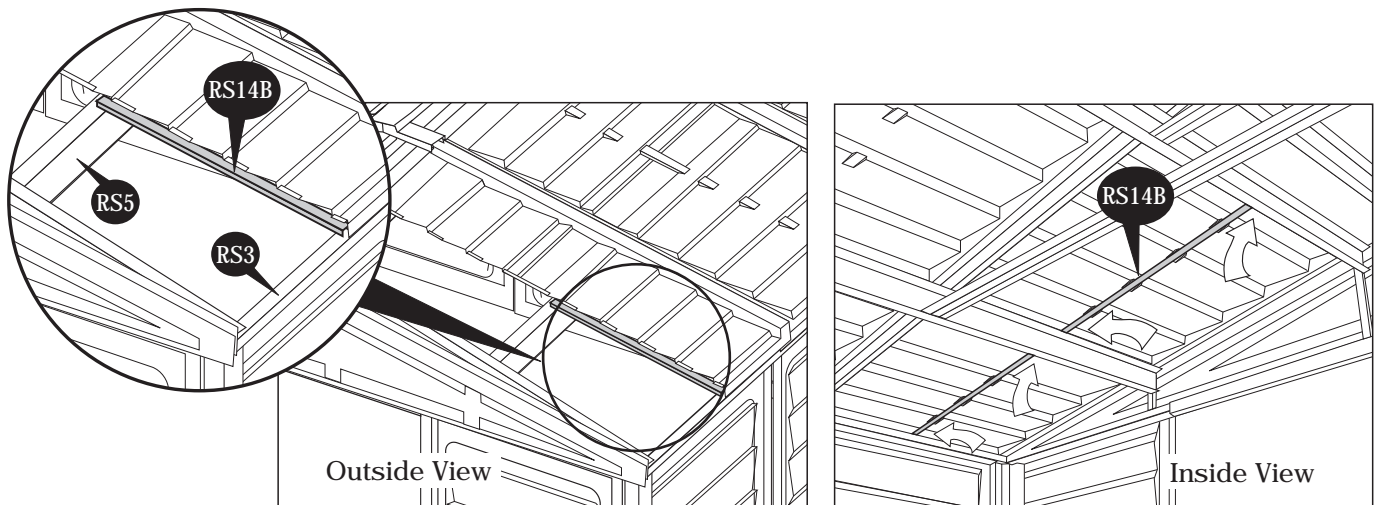

E. Doors

Parts Needed:

- (1) Door Left
- (1) Door Right

1. Attach the doors left and right (see fig.1) with Loose pin hinges on door columns (CDLB) and (CDRB).

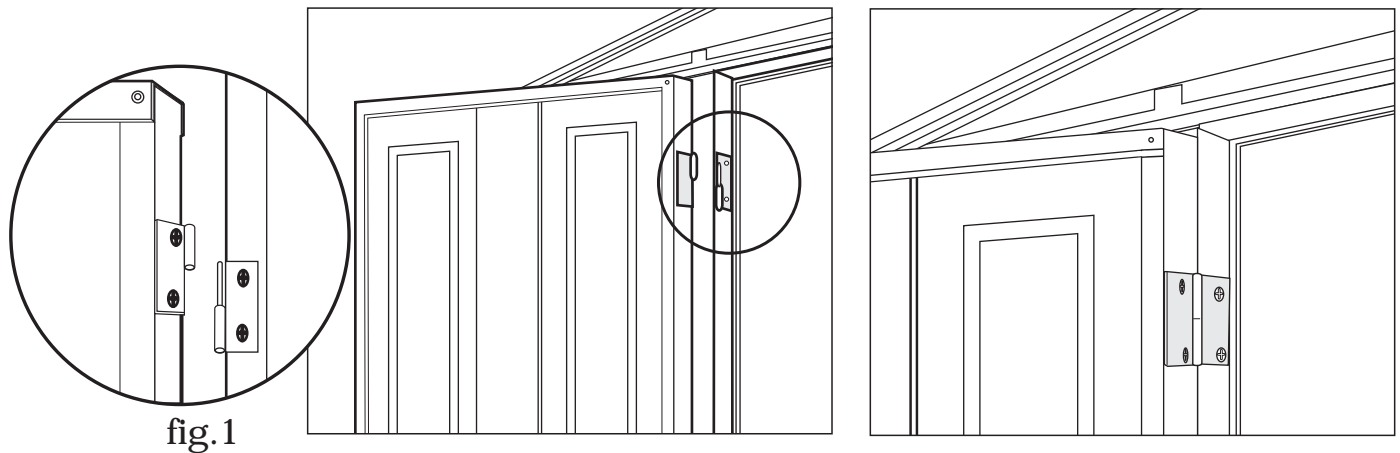

Note: To prevent water leakage it is important that these instructions are followed.

1. After completing the assembly apply silicone around the perimeter of the base U-channel. Seal the corners, joints and base of door column also.

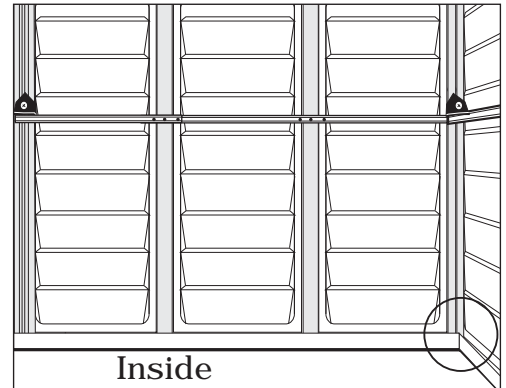
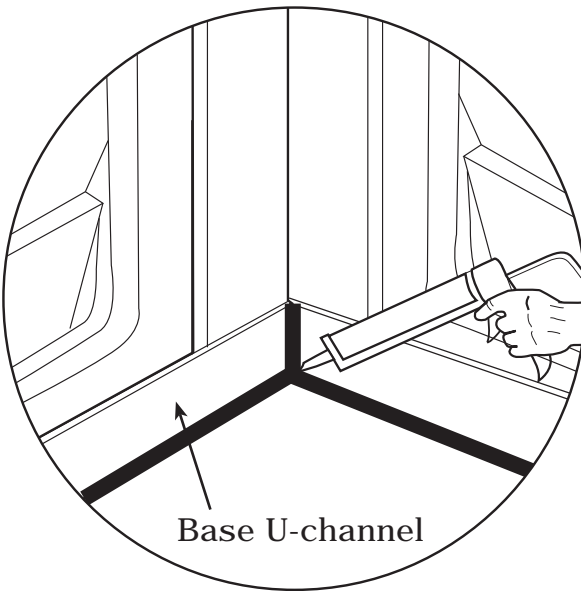

2. After completing the panel assembly, apply silicone around the roof plugs. This is optional and should be done for heavy rain areas if needed.

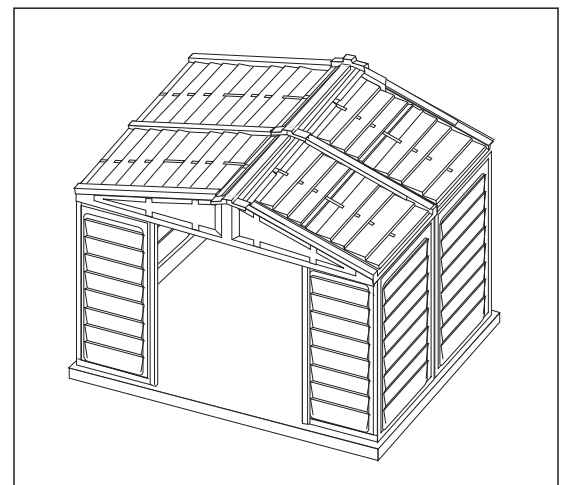
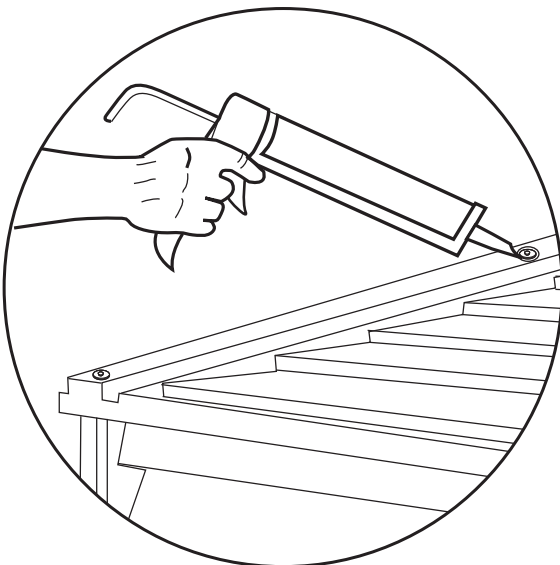

F. Optional Ventilation Kit

ACCESSORIES

CODE	DESCRIPTION	QTY
VC	VENTILATION COVER	2
VCP	VENTILATION COVER PIN	4

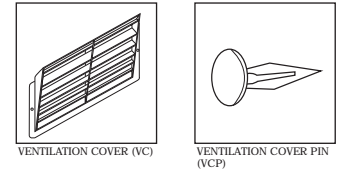

TOOLS YOU WILL NEED

Power Drill
 Dia 5/32" (4.2mm) drill bit
 Dia 1/2" (12.5mm) drill bit

Optional ventilation kits can be installed on any of the wall panels. However, we recommend mounting them on the top of the shed's back wall.

1. Place the ventilation cover (VC) as shown in fig.1. Using a pencil, mark the two side hole locations.

2. On the marked hole locations, drill out two holes using dia. 5/32" (4.2mm) drill bit as shown in fig.2. These holes will be used to attach the ventilation cover with the ventilation cover pins (VCP).

3. Use a dia. 1/2" (12.5mm) drill bit to drill out as many holes as desired behind the ventilation cover mounting area as in fig.3.

4. Attach the ventilation cover (VC) with the ventilation cover pin (VCP) as in fig.4.

5. Repeat the same to fix the second ventilation cover.

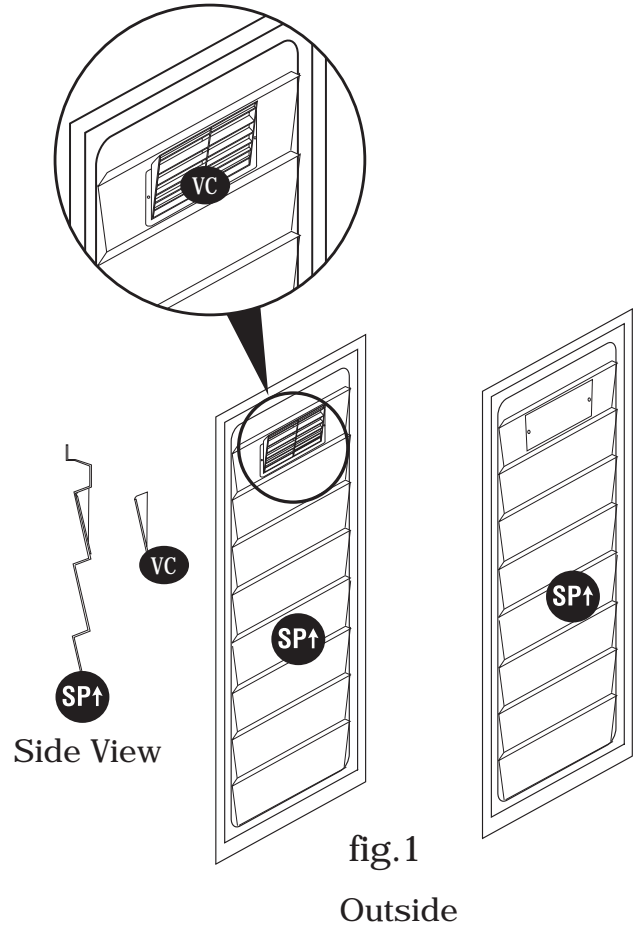

fig.1
 Outside

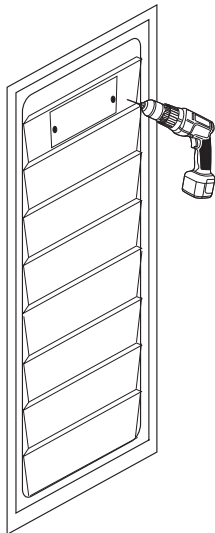

fig.2

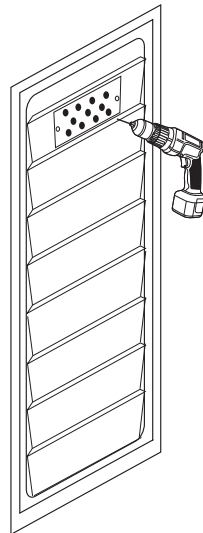

fig.3

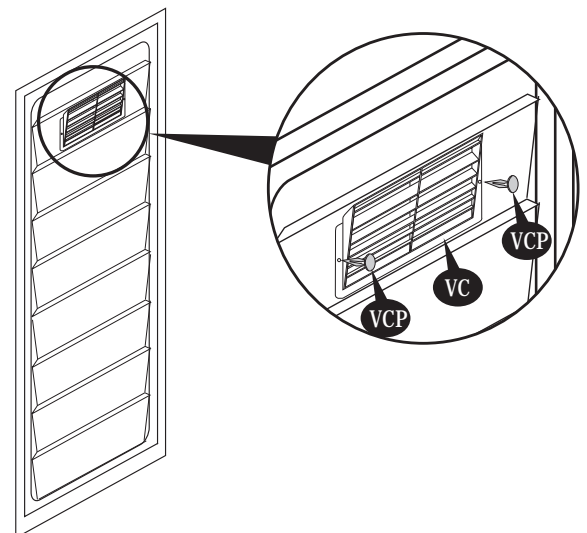

fig.4

High wind area installation instructions

Note: To ensure that your shed withstands high winds, you will need the following reinforcement.

Parts needed:

CODE	DESCRIPTION	QTY
S4	DIA. 4.2 x 16mm. (5/32" x 5/8") SHEET METAL SCREW	36 (not included with shed)
S5	M6 x 40mm. (1/4" x 1 1/2") Anchor bolt with nut	22 (not included with shed)

1. Shed or shed foundation should be placed on concrete footing by use of anchor bolt and nut. Using a carpenter's square, line up corners. Align U-Channel base, mark the concrete through the holes in the base and drill concrete with 1/2" (dia. 12.5mm) concrete bit to accept anchor bolts to a 1 3/4" (44mm) depth. Replace base and secure with 1/4" x 1 1/2" (M6 x 40mm) anchor bolts. See fig.

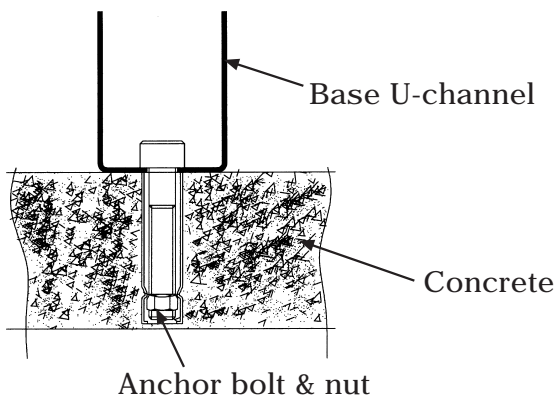
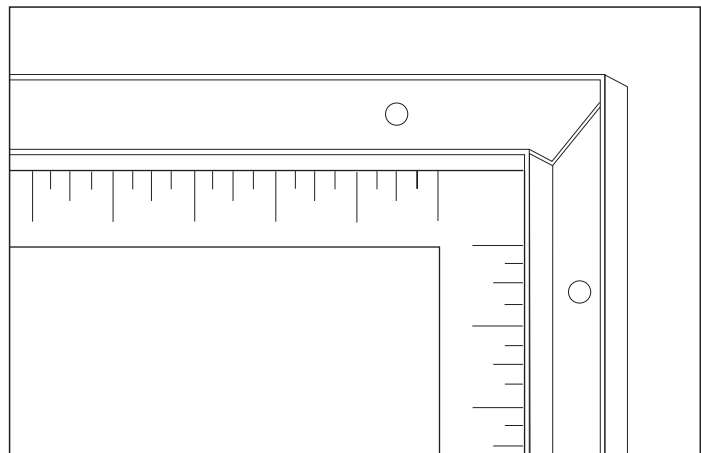

2. Attach each side panel (SP↑) on the bottom to the U-channel base. Using a dia. 3mm (1/8") drill with a power drill, make two equal distance holes on the U-channel base through the side panel. Drive a self tapping screw (S4) through the base U-channel to the side panel. Repeat this for every side panel. See blowup.

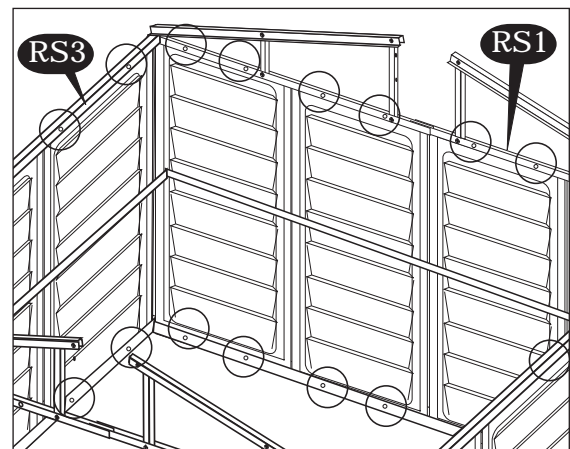
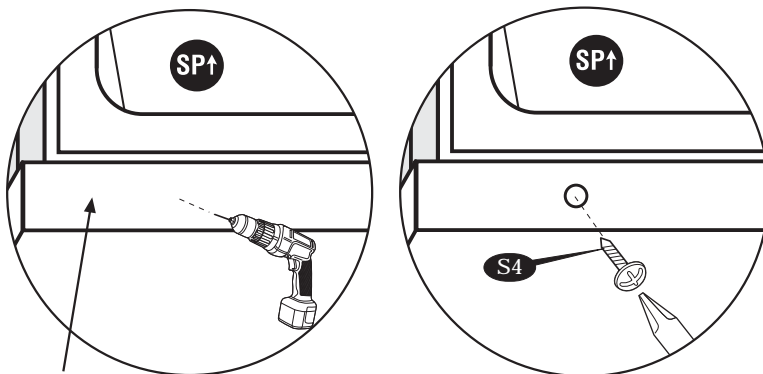

3. Attach each side panel (SP↑) on top to the roof structure (RS1) and (RS3). Using a dia. 3mm (1/8") drill with a power drill, make two equal distance holes on the side panel through the roof structure. Drive a self tapping screw (S4) through the side panel to the roof structure. Repeat this for every side panel. See blowup.

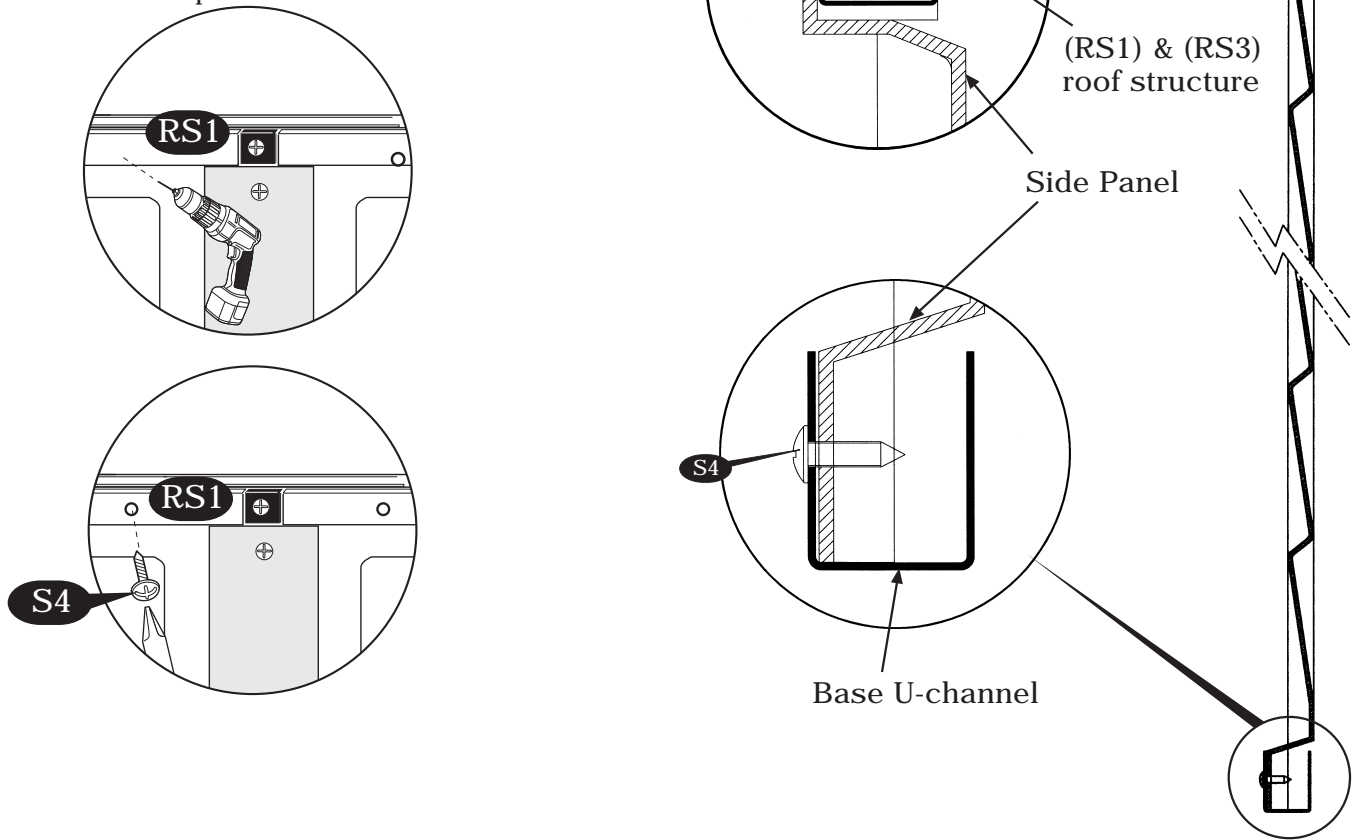

Important Warranty Information

The Duramax shed has been tested and passed wind loads of up to 115 mph in a controlled laboratory environment. Natural high wind areas create wind at unpredictable speeds that are very difficult to capture accurately by location. As such we cannot guarantee the performance of the shed in these extreme situations.

Foundation Kit

Instructions for Assembly Size 8' x 6'

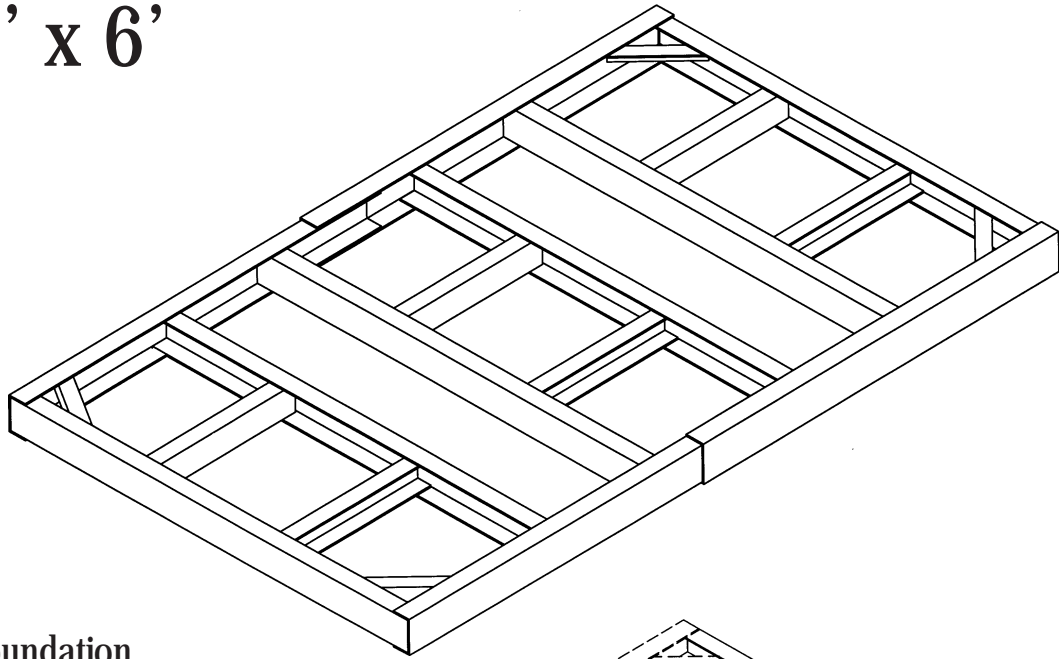

PART 1 :
8' x 6' Foundation
Assembly Instruction

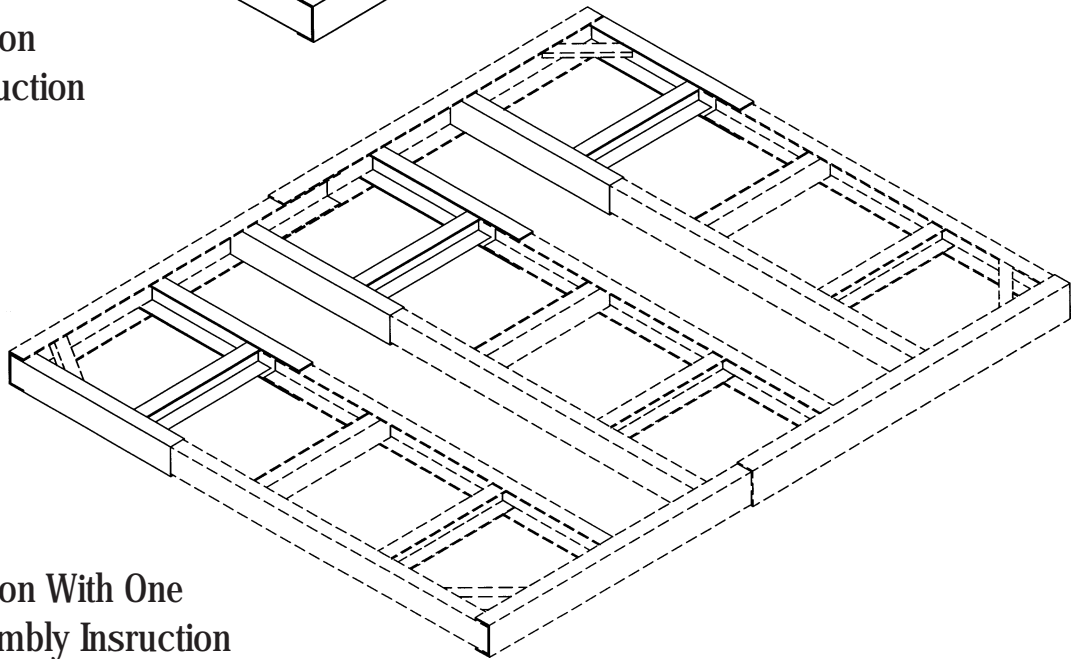

PART 2 :
8' x 6' Foundation With One
Extension Assembly Instruction

TOOLS YOU WILL NEED

- Cordless Drill - Philips Head

PART 1 : 8' x 6' Foundation Assembly

1. Assemble the channel (F01B) & (F02B) together using 4 screws. Make 2 sets.

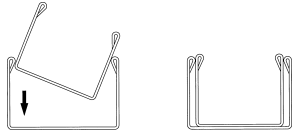
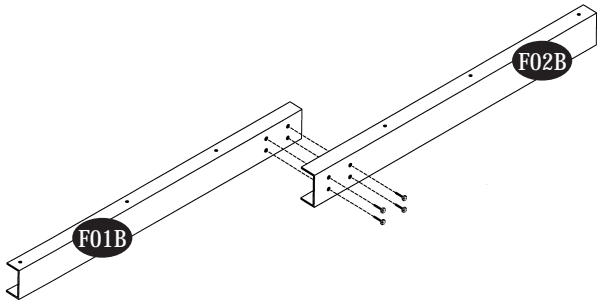

Parts List

Note: Check all parts prior to installation.

CODE	DESCRIPTION	QTY
F01B	FOUNDATION 'U' CHANNEL	2
F02B	FOUNDATION 'U' CHANNEL	2
F03	FOUNDATION 'L' ANGLE	4
F04B	FOUNDATION 'U' CHANNEL	6
F05B	FOUNDATION 'U' CHANNEL	6

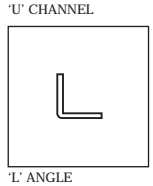
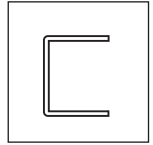

ACCESSORIES

CODE	DESCRIPTION	QTY
S1	DIA. 4.2 x 16mm. (5/32" x 5/8") SHEET METAL SCREW	64

2. Make a frame with the sub assemblies as shown below.

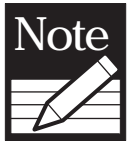

Make sure while assembling, the channel position should be as shown.

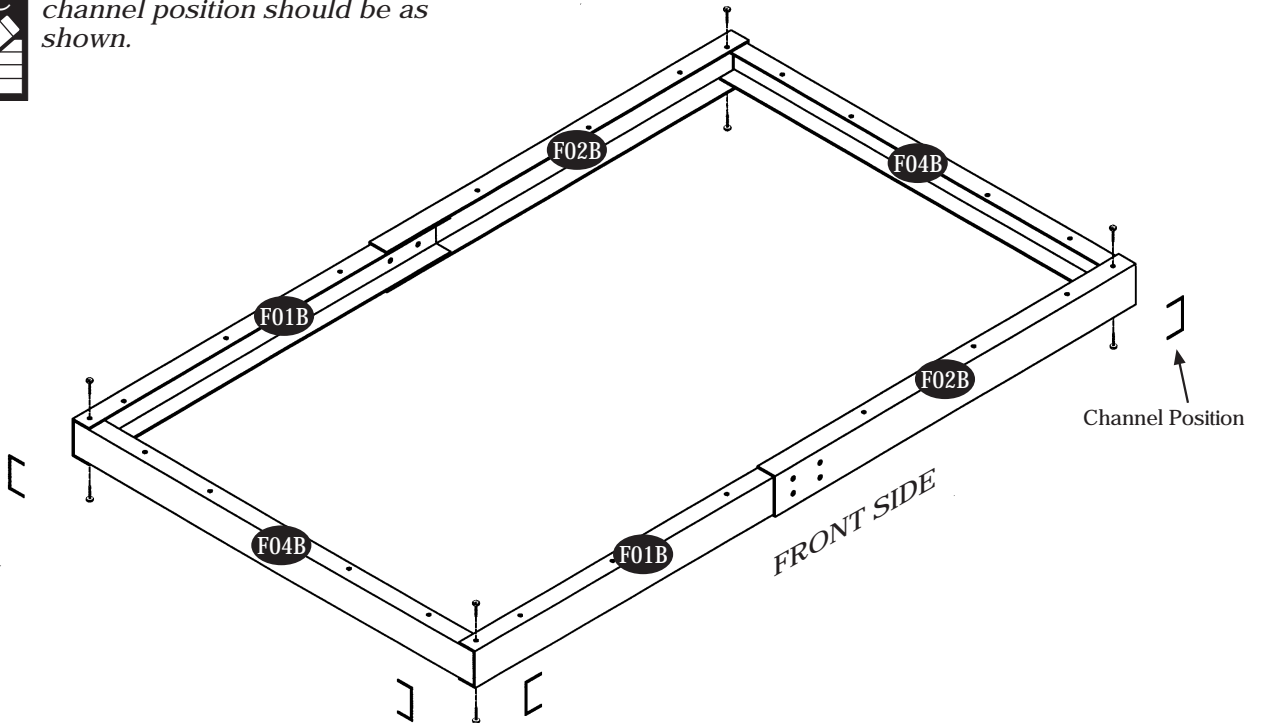

3. Fix the L-angle (F03) to the channel at all the four corners to make a perfect frame. See Fig.

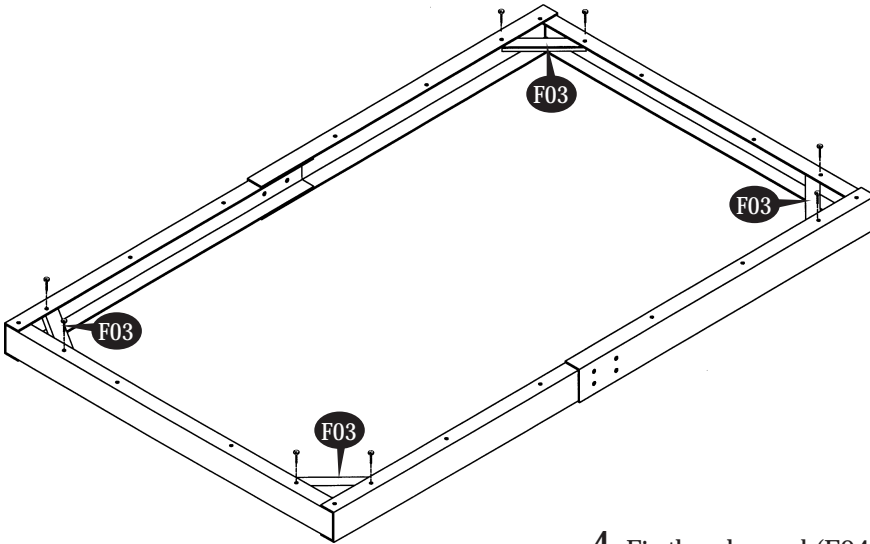

4. Fix the channel (F04B) into the main frame as shown. See Fig.

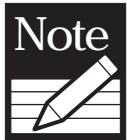

Note Make sure while assembling, the channel position should be as shown.

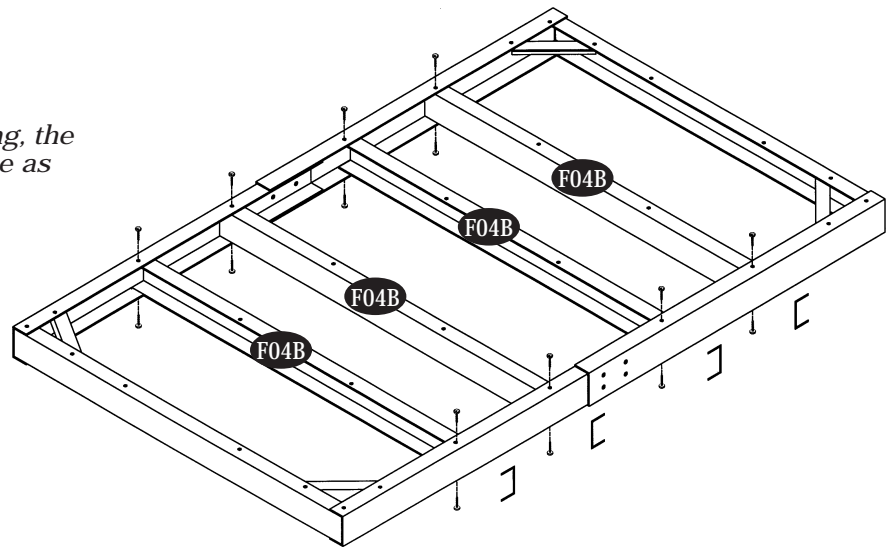

5. Fix the channel (F05B) into the frame with screws as shown. See Fig.

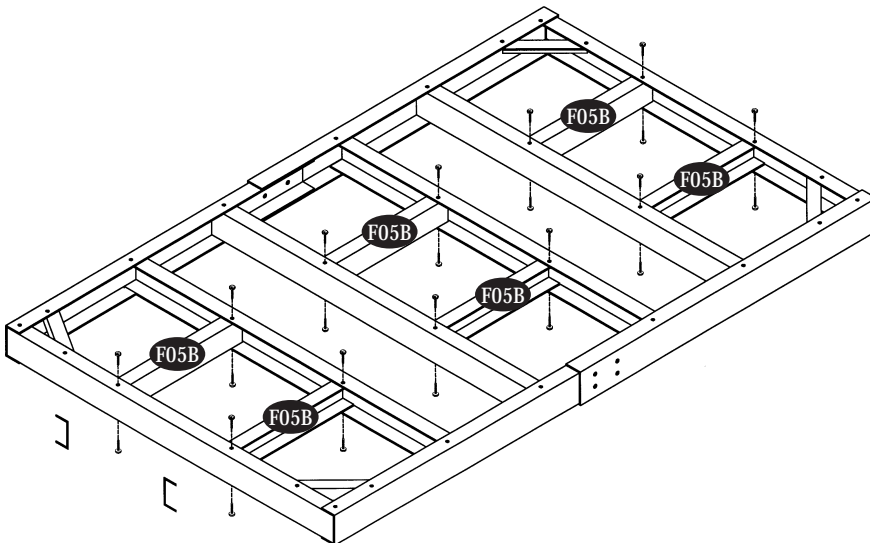

6. Assemble the U-Channel bases on top of the foundation as shown in Figure.

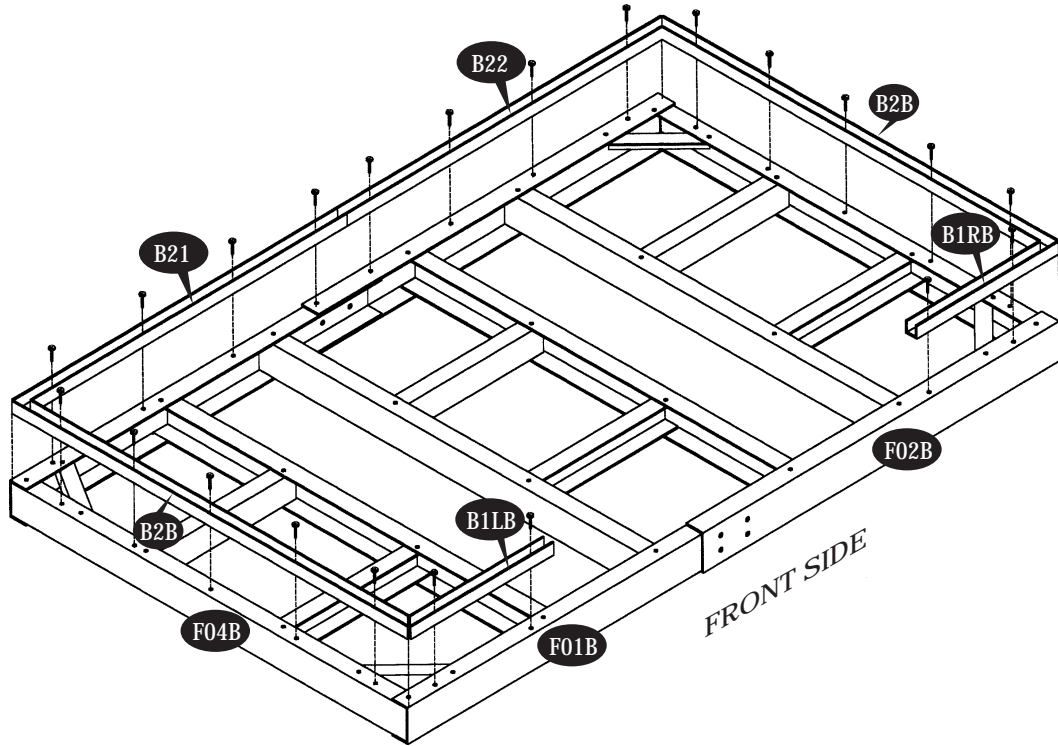

7a. After completing the assembly of shed place exterior grade CDX 3/4" (19mm) plywood inside the foundation. See fig.

OR 7b. After completing the assembly of the base U-channel fill the concrete upto the foundation top surface.

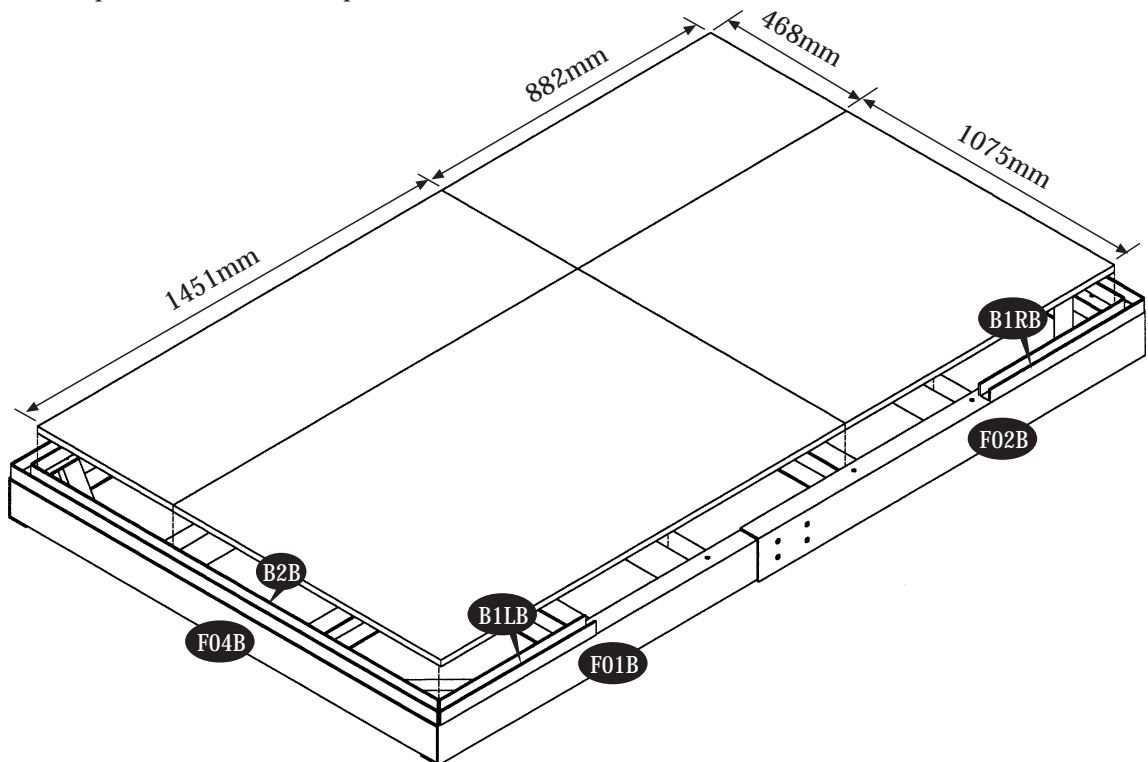

PART 2 : 8' x 6' Foundation With One Extension Assembly

1. Assemble the channel (F01B) & (F02B) together using 4 screws. Make 2 sets.

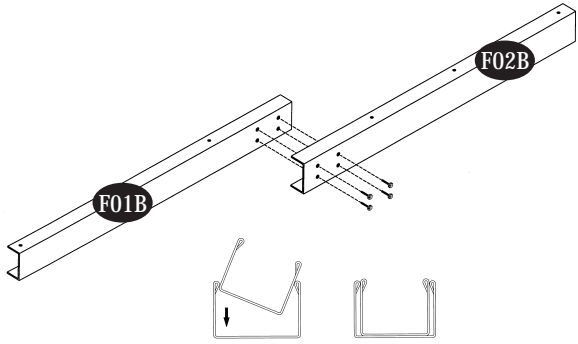

Parts List

Note: Check all parts prior to installation.

CODE	DESCRIPTION	QTY
F05B	FOUNDATION 'U' CHANNEL	3
F07	FOUNDATION 'U' CHANNEL	6

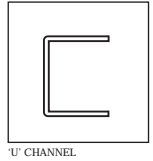

2. Assemble the channel (F04B) & Extension (F07) together with screws. Make 6 sets.

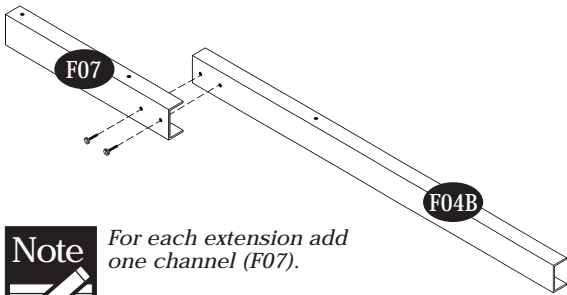

ACCESSORIES

CODE	DESCRIPTION	QTY
S1	DIA. 4.2 x 16mm. (5/32" x 5/8") SHEET METAL SCREW	24



Note For each extension add one channel (F07).

3. Make a frame with the sub assemblies as shown below.

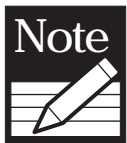

Note Make sure while assembling, the channel position should be as shown.

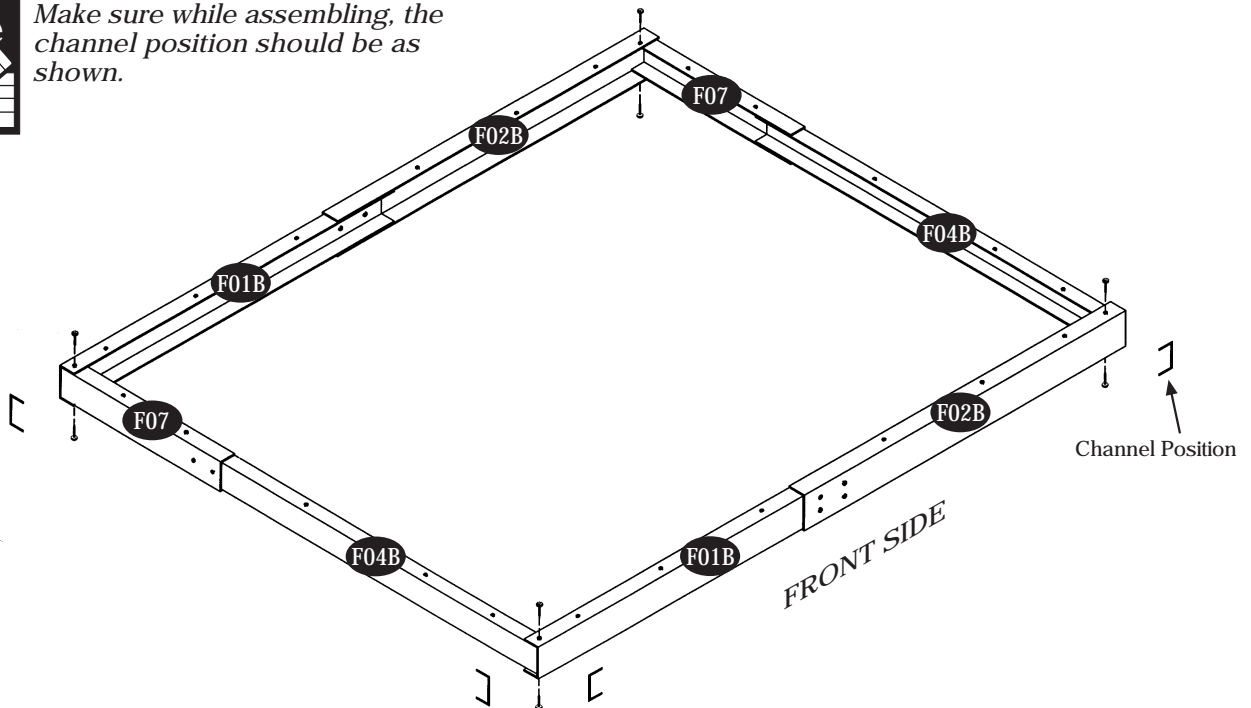

4. Fix the L-angle (F03) to the channel at all the four corners to make a perfect frame. See Fig.

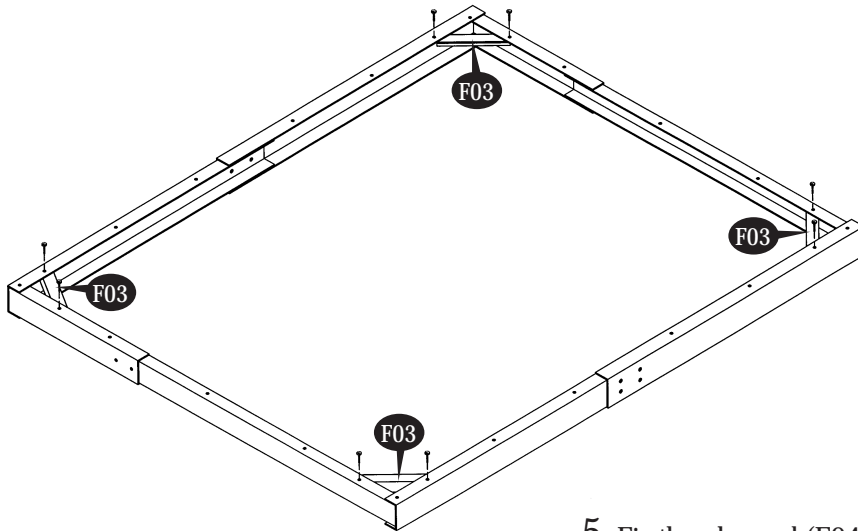

5. Fix the channel (F04B) & (F07) sub assembly into the main frame as shown. See Fig.

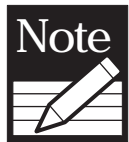

Make sure while assembling, the channel position should be as shown.

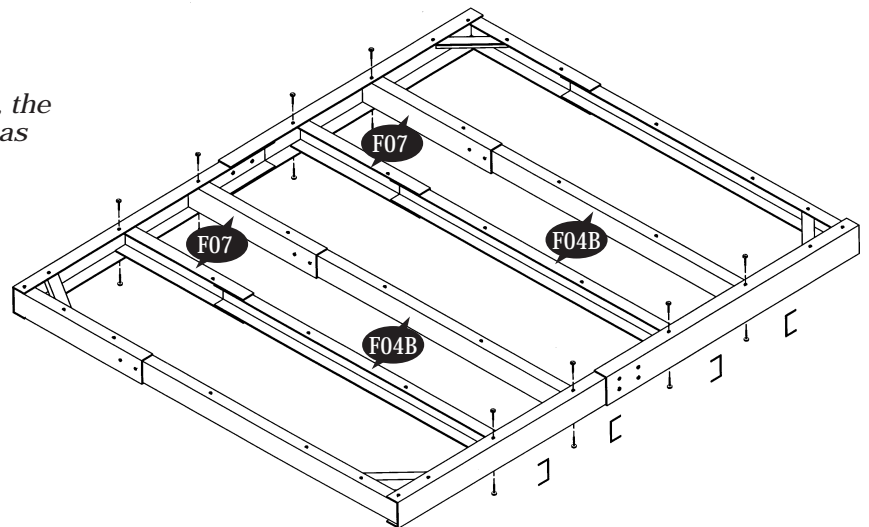

6. Fix the channel (F05B) into the frame with screws as shown. See Fig.

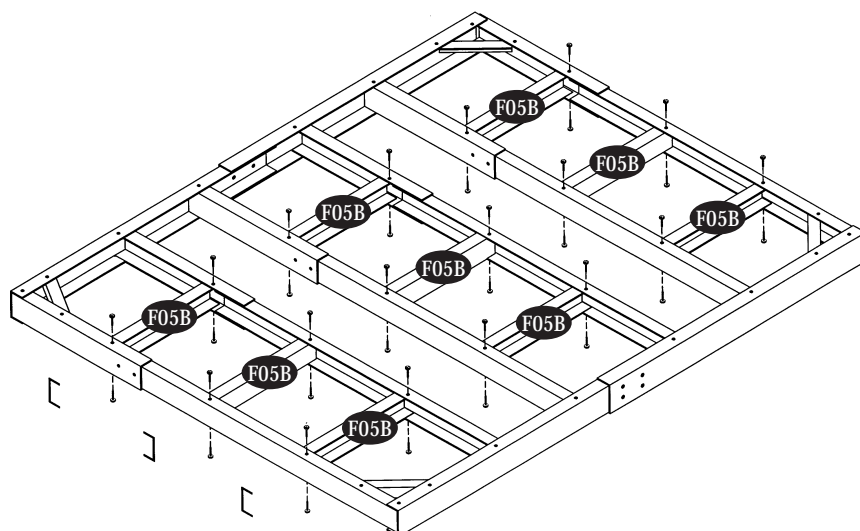

7. Assemble the U-Channel bases on top of the foundation as shown in Figure.

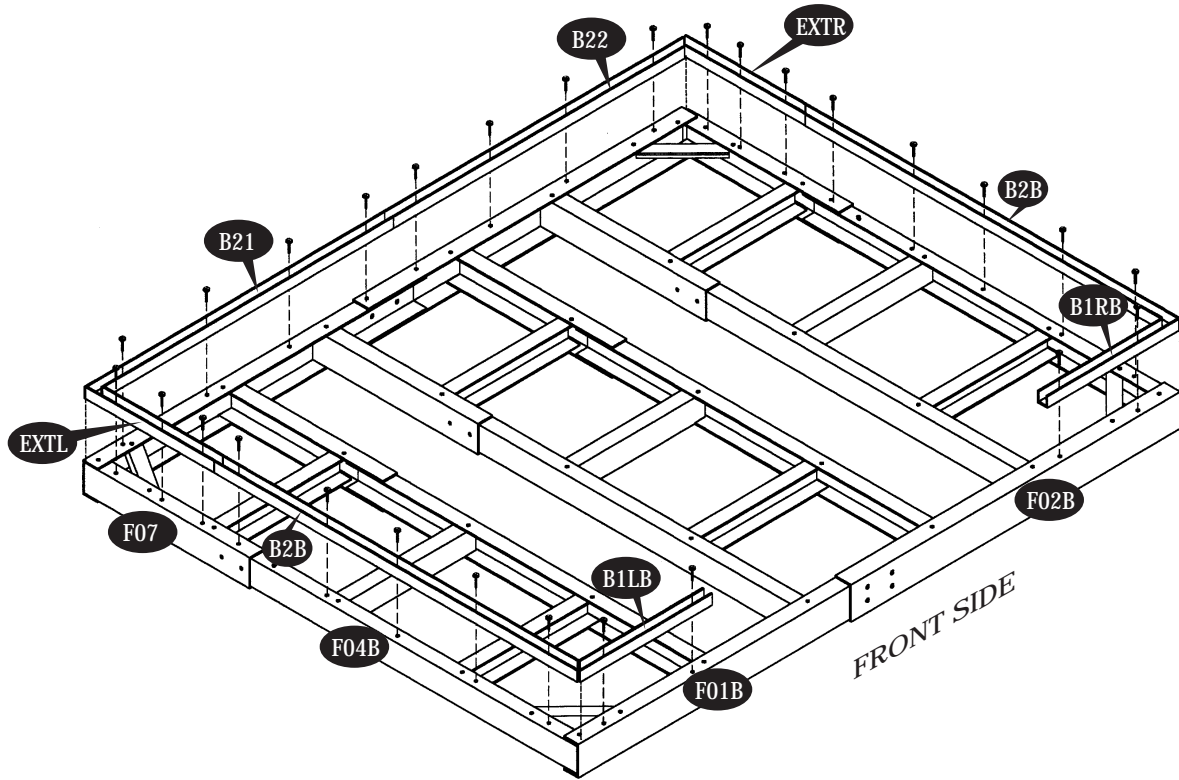

8a. After completing the assembly of shed place exterior grade CDX 3/4" (19mm) plywood inside the foundation. See fig.

OR 8b. After completing the assembly of the base U-channel fill the concrete upto the foundation top surface.

