

Storage Shed

Patent #416.091

OWNER'S MANUAL / Instructions for Assembly Size 4' x 8'

Ver: 1.2

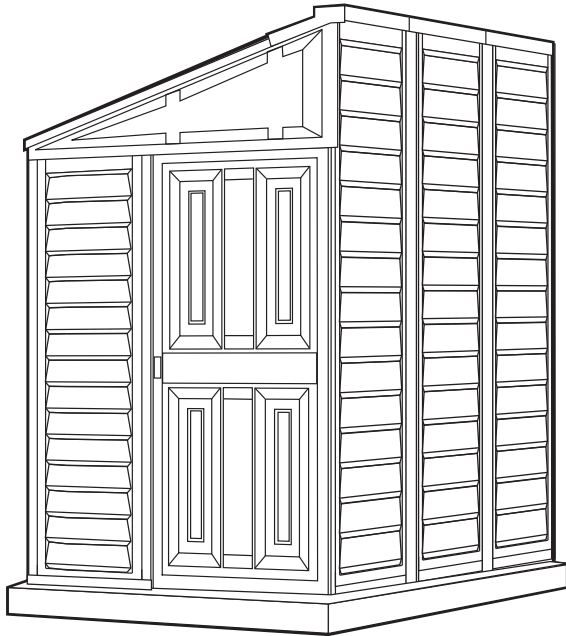

**Customer
Service Hotline
(800) 483-4674
www.uspolymersinc.com**

Your Total Solution To Maintenance Free Storage Sheds.

- All Weather Durable PVC
- High Head Room For Garden Implements
- Won't Dent, Rust, Rot or Mildew
- Never Needs Painting
- Wide Single Door
- Easy Assembly
- Pad Lock Ready (Lock not included)
- Wooden or Cement Foundation Needed

Requires two people and takes about
3-4 hours for Installation.

Available Kits

- Foundation Kit Available
- Window Kits Available

Call us for any missing or damaged parts.
Do not return to the store.

Duramax Storage Shed Limited Fifteen Year Warranty

U.S. Polymer Inc. will send a replacement part free of charge, in the event of material defects and or workmanship for a period of fifteen years from the date of purchase.

This warranty is extended only to the original purchaser. A purchase receipt or other proof of date of original purchase will be required before warranty service is rendered. In no event shall we pay the cost of flooring, labor, installation or any other costs related thereto.

This warranty only covers failures due to defects in material or workmanship which occurs during normal use and does not extend to color change arising due to normal weathering or to damage resulting from misuse or neglect, commercial use, failure to follow assembly instructions and the owner's manual (including proper anchoring of the shed), painting, forces of nature and other causes which is beyond our control.

Claims under this warranty must be made within the warranty period by calling 1-800-483-4674 or mail in a dated sales slip and clear photograph of the part to:

U.S. Polymers, Inc.
6915 Slauson Avenue
Commerce, CA 90040

We reserve the right to discontinue or change components. If a component has been discontinued or is not available,

U.S. Polymers, Inc. reserves the right to substitute a component of equal quality as may be compatible.

Limits and Exclusions

There are no express warranties except as listed above. The warrantor shall not be liable for incidental or consequential damages resulting from the use of this product, or arising out of any breach of this warranty.

All express warranties are limited to the warranty period set forth above. Some states do not allow the exclusion or limitation on how long an implied warranty lasts, so the above limitations may not apply to you.

This warranty gives you specific legal rights and you may also have other rights which vary from state to state or country to country.

Parts List

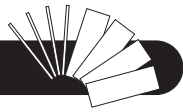

Note: Check all parts prior to installation.

ACCESSORIES

CODE	DESCRIPTION	QTY	CODE	DESCRIPTION	QTY
B1C	FRONT 'U' CHANNEL	1	FDCLC	DOOR COLUMN FITTING LEFT	1
B21	SIDE 'U' CHANNEL	2	FCC	CORNER COLUMN FITTING	2
B22	SIDE 'U' CHANNEL	1	FMC	MIDDLE COLUMN FITTING	3
B3C	BACK 'U' CHANNEL	1	FCB	CENTER BAND FITTING	3
B4C	SIDE 'U' CHANNEL	1	FMRC	ROOF STRUCTURE FITTING	4
CMB	MIDDLE COLUMN SHORT	3	FRLC	'L' BRACKET	2
CMC	MIDDLE COLUMN LONG	2	FRTC	'T' BRACKET	1
CCB	CORNER COLUMN SHORT	2	FCB5C	CB5 FITTING	1
CCC	CORNER COLUMN LONG	1	RJ	90 DEGREE JOINT	2
CDLC	DOOR COLUMN LEFT SHORT	1	PPG	ROOF PLUG	52
CDRC	DOOR COLUMN RIGHT LONG	1	PWS	ROOF PLUG WASHER	52
CB1C	FRONT CENTER BAND	1	PIN	ROOF PIN	52
CB2C	BACK CENTER BAND	1	EPS	END PLUG SQUARE	4
CB3LC	LEFT SIDE CENTER BAND	1	S1	DIA. 4.2 x 16mm. (5/32" x 5/8")	149
CB3SC	SIDE CENTER BAND SHORT	2	S2	DIA. 4.2 x 32mm. (5/32" x 1 1/4")	
CB4C	FRONT BOTTOM CROSS CENTER BAND	1	S3	M4 x 10mm. (M5/32" x 3/8")	16
CB5C	RIGHT SIDE CENTER BAND	1		MACHINE SCREW WITH NUT	
CB6C	FRONT TOP CROSS CENTER BAND	1			
RS1C	RS1 ROOF STRUCTURE	2			
RS2FC	RS2 FRONT ROOF STRUCTURE	1			
RS2BC	RS2 BACK ROOF STRUCTURE	1			
RS3LC	RS3 ROOF STRUCTURE LONG	1			
RS3SC	RS3 ROOF STRUCTURE SHORT	1			
RS4C	RS4 ROOF STRUCTURE	2			
RS5C	RS5 ROOF STRUCTURE	2			
RS6C	RS6 ROOF STRUCTURE	2			
RS8C	RS8 ROOF STRUCTURE SUPP LONG	2			
RS9C	RS9 ROOF STRUCTURE SUPP SHORT	2			
RS14C	SAGGING SUPPORT	6			
DSHC	DOOR STOPPER HORIZONTAL	1			
FSP^	HALF SIDE PANEL	2			
SP^	SIDE PANEL SHORT	4			
SPC^	SIDE PANEL LONG	3			
FPLC	FACIA PANEL LEFT	1			
FPRC	FACIA PANEL RIGHT	1			
RP^	ROOF PANEL	3			
RRSC	RIDGE COVER	3			
DR	DOOR	1			

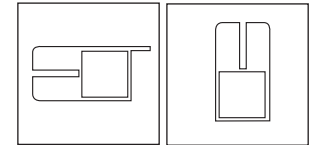

DOOR COLUMN LEFT (CDLC) DOOR COLUMN RIGHT (CDRC)

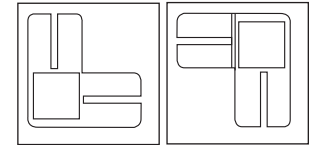

CORNER COLUMNS (CCB) CORNER COLUMN (CCC)

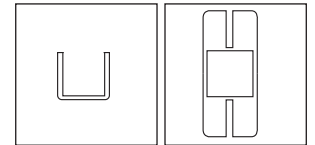

ROOF STRUCTURES (RS - 1C, 3LC, 3SC, 8C, 9C) (CB-1C, 2C, 3LC, 3SC, 4C, 5C, 6C) MIDDLE COLUMNS (CMB) (CMC)

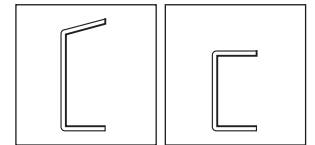

ROOF STRUCTURE (RS5C) (RS6C) DOOR STOPPER (DSHC)

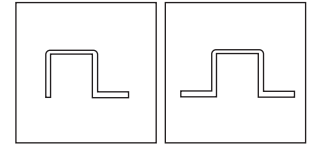

ROOF SUPPORT (RS2FC) (RS2BC) ROOF SUPPORT (RS4C)

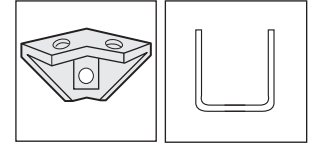

CENTER BAND FITTING (FCB) U-Channels (B1C) (B3C) (B21) (B22) (B4C)

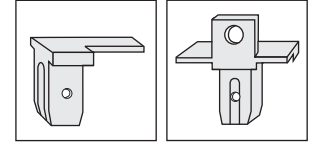

DOOR COLUMN FITTING (FDCLC) MIDDLE COLUMN FITTING (FMC)

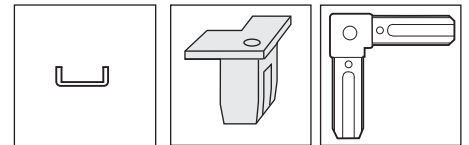

SAGGING SUPPORT (RS14C) CORNER COLUMN FITTING (FCC) PVC 90 DEGREE JOINT (RJ)

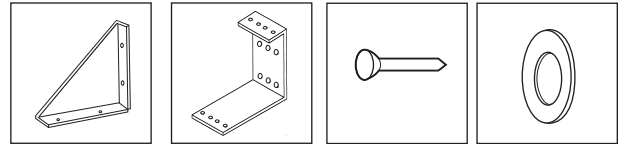

'L' BRACKET (FRLC) ROOF STRUCTURE FITTING (FMRC) ROOF PIN (PIN) ROOF PLUG WASHER (PWS)

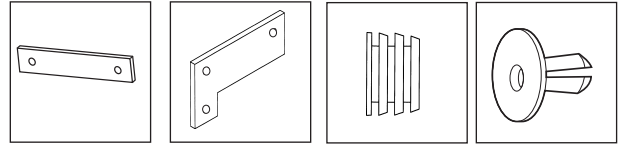

CBS FITTING (FCB5C) 'T' BRACKET (FRTC) END PLUG SQUARE (EPS) ROOF PLUG (PPG)

Tools You Will Need

- Cordless Drill - Philips Head
- Hammer or Rubber mallet
- Carpenters Square
- 8' Step Ladder
- Adjustable pliers
- Level - 3ft.
- Tape Measure
- Caulk Gun
- Waterproof Clear Silicon
- Sealant
- Hand Gloves

Exploded View

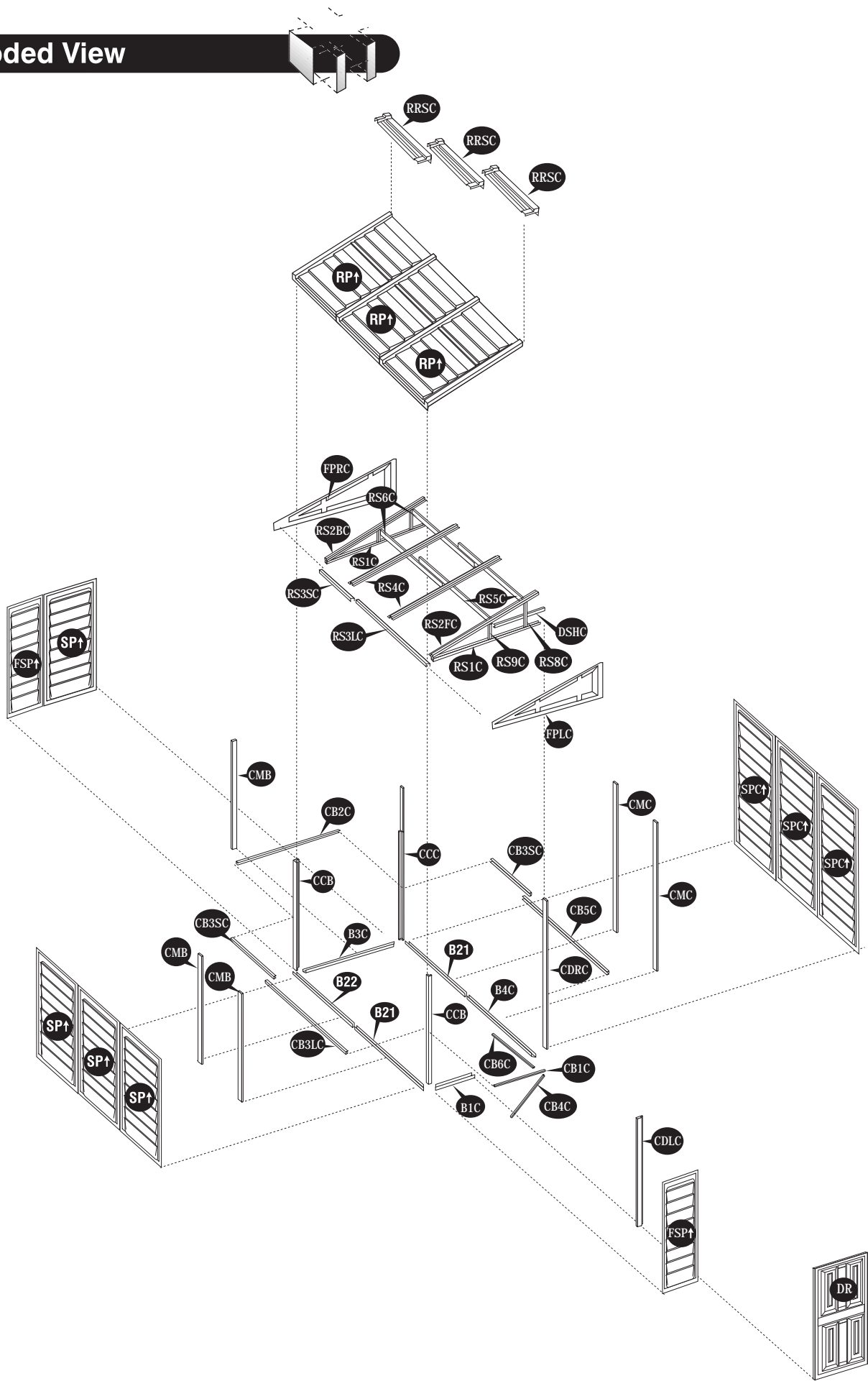

A. Foundation & Base Frame

Note: It is important that these instructions are followed step by step.

DuraMax must be installed on a level wooden platform or a level concrete foundation.



Wooden platform is extra and is not included. Don't install under windy conditions.

Parts needed:

- (1) Front U channel (B1C)
- (2) Side U channel (B21)
- (1) Side U channel (B22)
- (1) Back U channel (B3C)
- (1) Side U channel (B4C)
- (22) Dia. 4.2 x 16mm Screws (S1)

1. Use pressure treated 2" x 4" (5cm x 10cm) to build a foundation structure that has an outside dimension of 48" x 96" (1219.2mm x 2438.4mm).

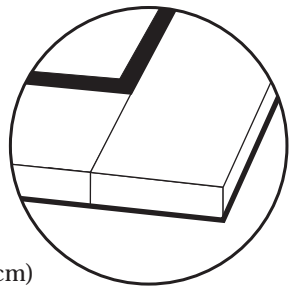

Lay 2" x 4" Flat (5 x 10cm)

2. Using exterior grade CDX 3/4" (19mm) plywood, cut and fit together the sheets to form solid plywood floor as shown. Foundation must be square and level.

3. Start with U-Channel bases (B3C) to insure a quick and accurate layout. Position all U channel bases on wood foundation. It is critical that you allow 30 1/4" (767mm) between front bases (B1C) and (B4C) for door placement. Measure in all directions as shown in fig.1. Make sure the U-channel assembly is a perfect square.

Wooden Platform (Not Included)

The following are a list of lumber and sizes you will need.

- Pressure Treated-Wood Studs: Exterior Grade (CDX):
 3ea 2" x 4" x 89" (50 x 88.9 x 2260.6mm) 3/4" (19mm) plywood
 2ea 2" x 4" x 48" (50 x 88.9 x 1219.2mm) 1ea 3/4" x 48" x 96"
 (19 x 1219.2 x 2438.4mm)

L-Brackets: 4ea

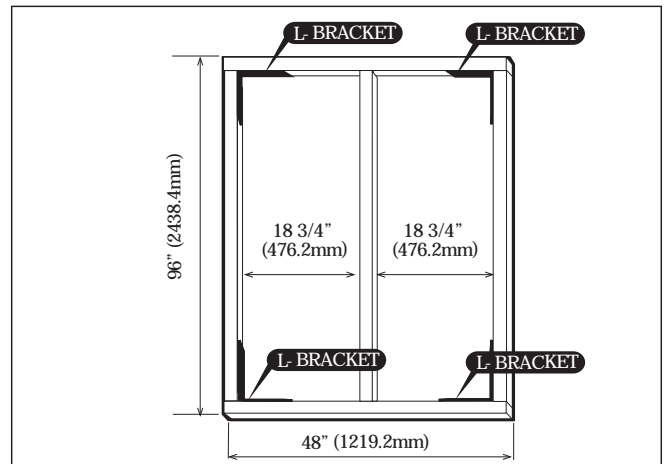

Foundation Structure

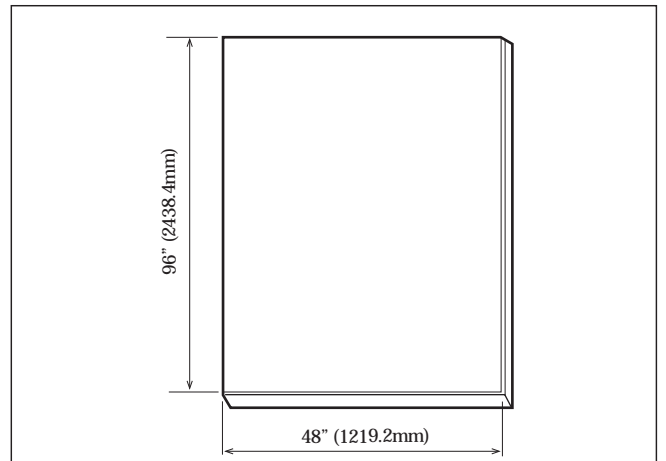

Plywood Floor

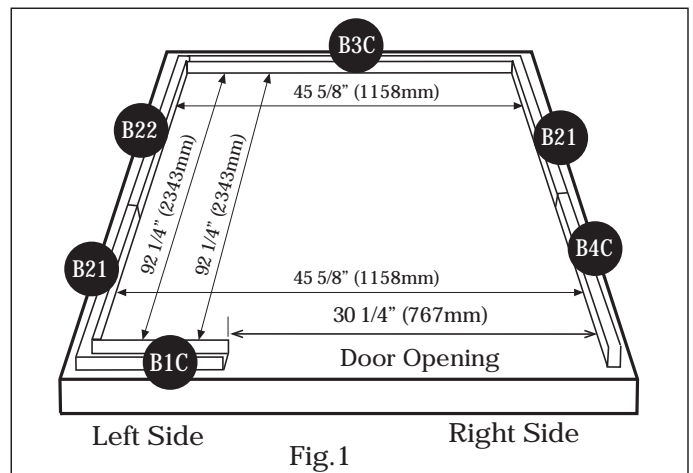
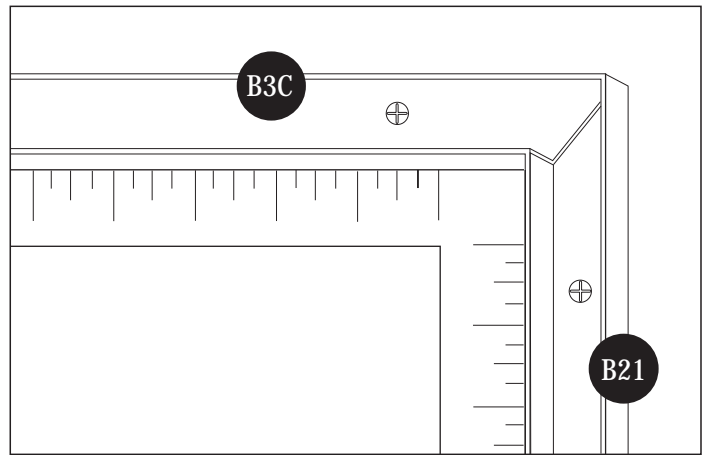

Fig.1
U-Channel Layout

4. Using a carpenter's square, line up all corners. Secure base to wood foundation using (S1) screws.

Concrete foundation

4b. (Concrete foundation) Using a carpenter's square, line up corners. Align U-Channel base, mark the concrete at the holes in the base and drill concrete with 1/4" (dia. 6mm) concrete bit to accept anchor bolts to a 1 3/4" (44mm) depth. Replace base and secure with 1/4" x 1 3/8" (M6 x 35mm) anchor bolts (not provided).



B. Walls & Columns



Note



All panels are clearly marked and care should be taken to use the correct one.

Parts Needed:

- | | |
|-----------------------------------|---|
| (2) Corner Column Short (CCB) | (1) Front Center Band (CB1C) |
| (1) Corner Column Long (CCC) | (1) Back Center Band (CB2C) |
| (1) Door Column Left Short (CDLC) | (1) Left Side Center Band (CB3LC) |
| (1) Door Column Right Long (CDRC) | (2) Side Center Band Short (CB3SC) |
| (3) Middle Column Short (CMB) | (1) Front Bottom Cross Center Band (CB4C) |
| (2) Middle Column Long (CMC) | (1) Right Side Center Band (CB5C) |
| (2) Half Side Panel (FSP↑) | (1) Front Top Cross Center Band (CB6C) |
| (4) Side Panels Short (SP↑) | (3) Center Band Fitting (FCB) |
| (3) Side Panel Long (SPC↑) | (1) CB5 Fitting (FCB5C) |

TIP



Layout all required parts near shed foundation.

1. Slide door column (CDLC) into the U-Channel Base (B1C). Line up the pre-drilled holes on (CDLC) Column with pre-drilled holes on U-Channel Base. Secure with two (S1) screws from inside. (See blowup detail)

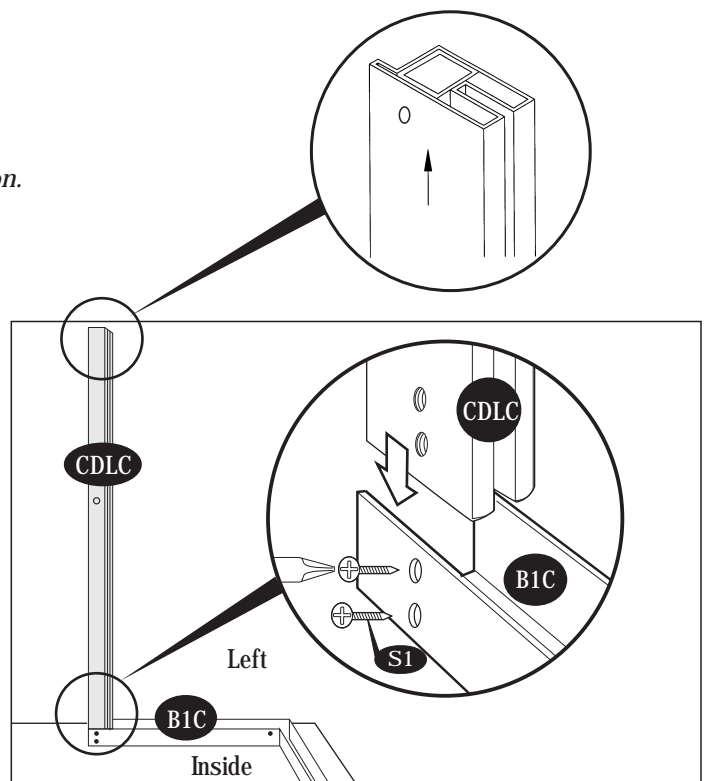

2. Insert the front side panel (FSP↑) into the groove of column (CDLC). Start at the bottom of the panel at an angle then push into place.



Always place panels into frame at an angle on top and slide in sideways and downward for easy insertion.

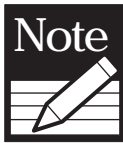

Make sure panels are right side up with panel shingles facing down. Check the stamped label on top of all panels.

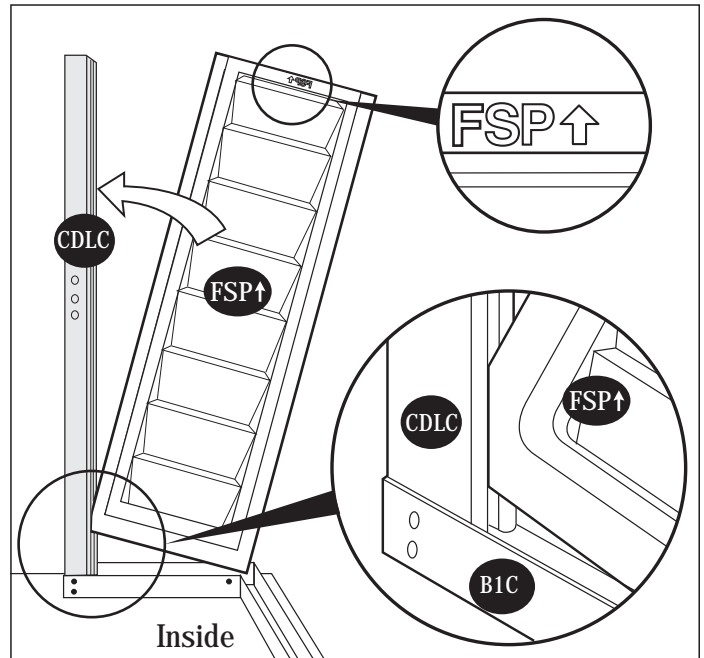
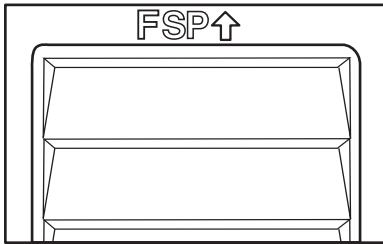

3. Slide corner column (CCB) into side panel (FSP↑) pushing the column to the side panel.

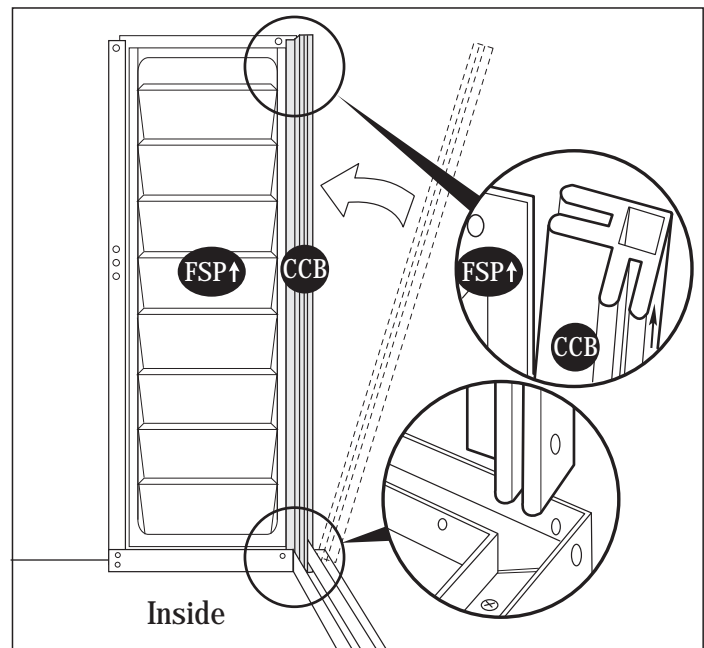

4. Working outside use (S1) screws to secure column to bases (B1C) and (B21).

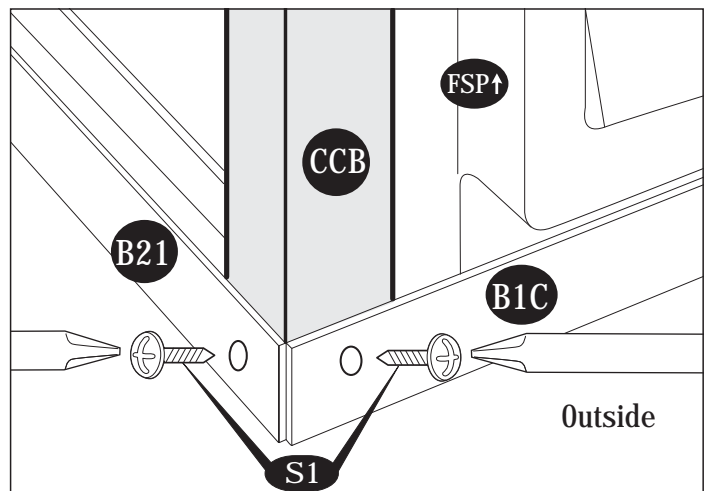

5. To stabilize the front panel attach the front center band (CB1C).
 Start with the center band fitting (FCB), fix to corner column (CCB) with (S2) screws. To continue See figures (fig.1) (fig.2) and (fig.3).

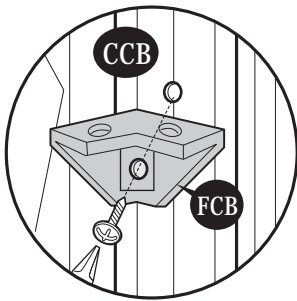
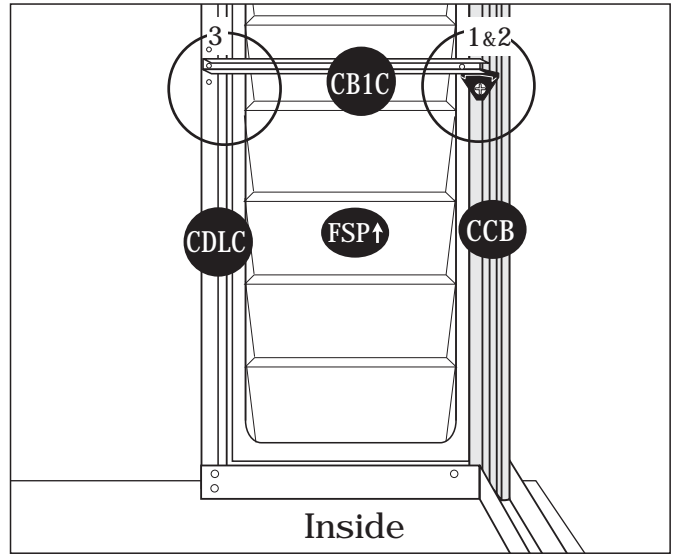

Fig.1: Use (S2) screw.
 Fix (FCB) to (CCB).
 Leave it loose.

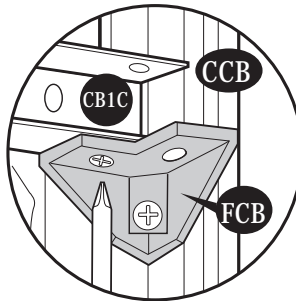

Fig.2: Use (S1) screw.
 Fix (CB1C) to (FCB).

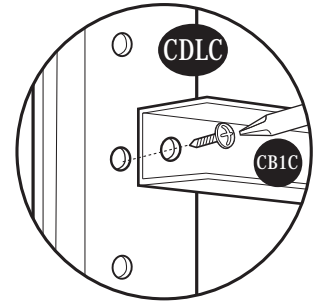

Fig.3: Use (S1) screw.
 Fix (CB1C) to (CDLC).

6. Attach center band (CB4C) to door column (CDLC) and base channel (B1C).

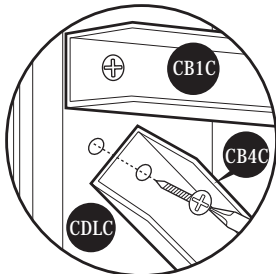

Fig.1: Use (S1) screw.
 Fix (CB4C) to (CDLC)

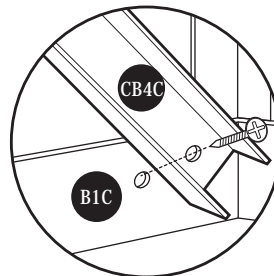

Fig.2: Use (S1) screw.
 Fix (CB4C) to base (B1C)

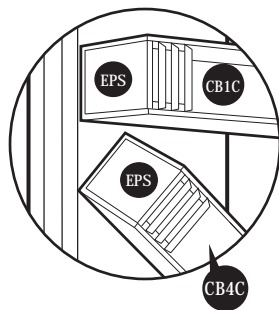
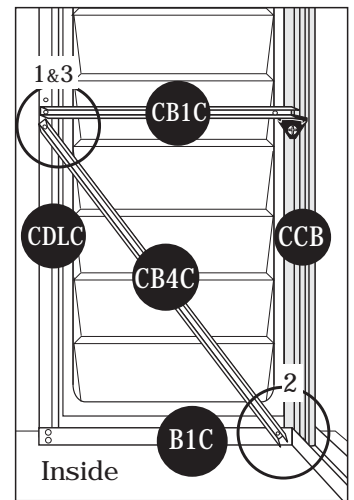
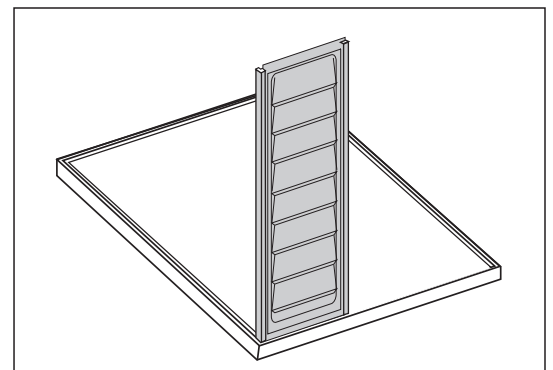
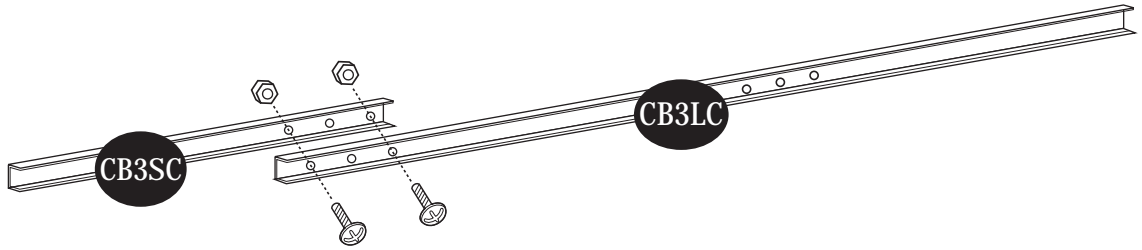

Fig.3: Fix the (EPS) at the end
 of (CB1C) & (CB4C).



7. Assemble the center bands (CB3SC) & (CB3LC) with (S3) screws with nuts. Follow Overlapping Method shown below.



8. Assemble the center bands (CB3SC) & (CB5C) with (S3) screws with nuts. Fix (FCB5C) to (CB5C) with (S3) screws with nuts. Follow overlapping method shown below.

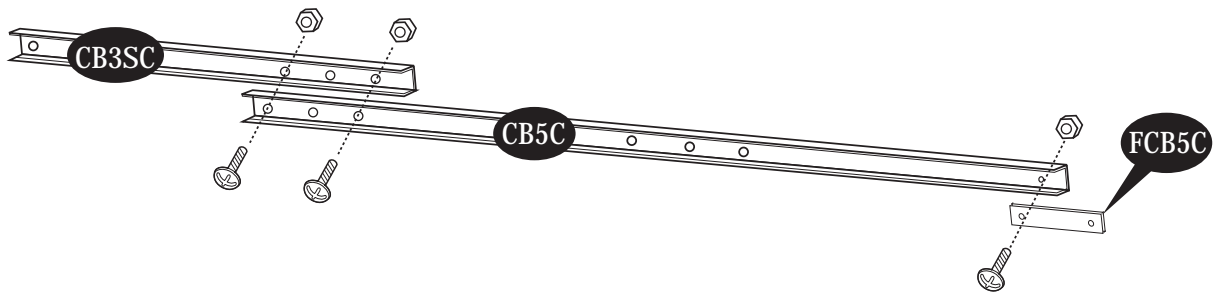

Overlapping Method

For Center Band, Roof structure (RS3LC) & (RS3SC).

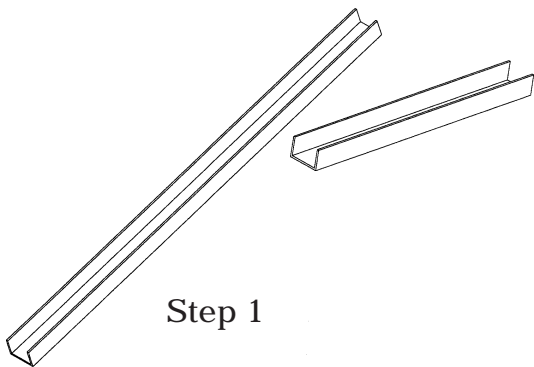

Step 1

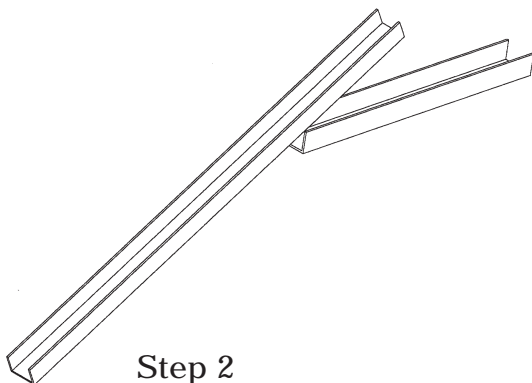

Step 2



Use a hammer to align the holes.

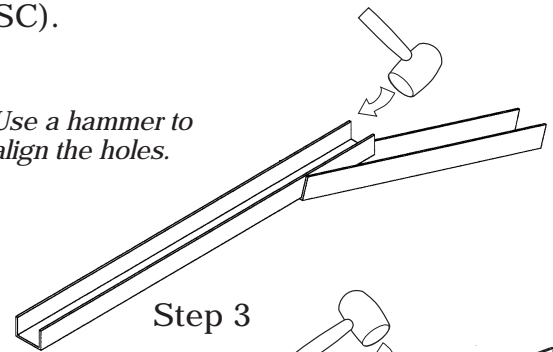

Step 3

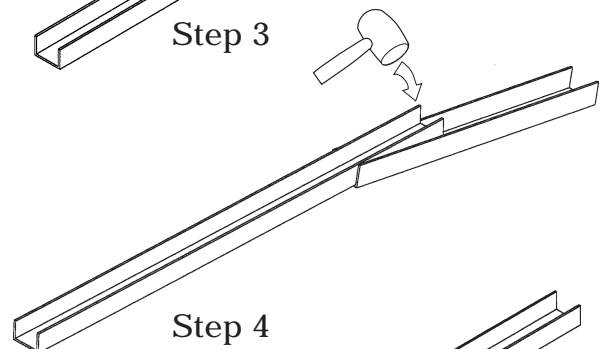

Step 4

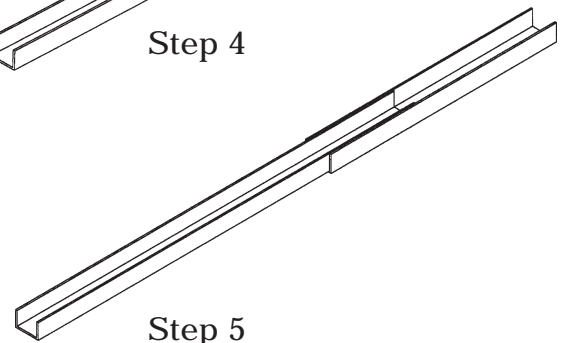

Step 5

9. Working from inside Continue connecting the 3 side panels (SP↑) and columns (CMB) in sequence along (B21 & B22) base. Use (S1) screws to fix columns to base.

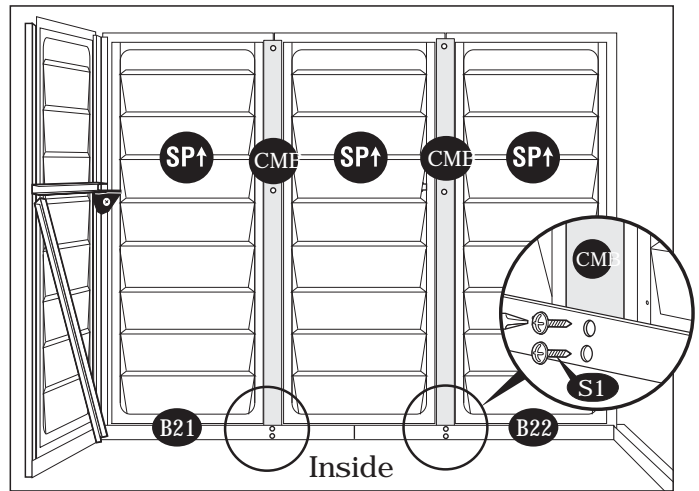

10. Slide corner column (CCB) into side panel (SP↑) pushing the column to the side panel.

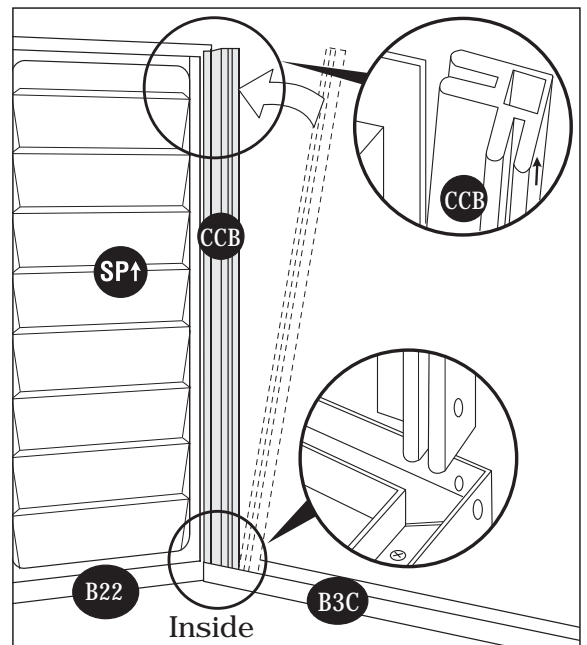

11. Working outside Use (S1) screws to secure column to bases (B22) and (B3C).

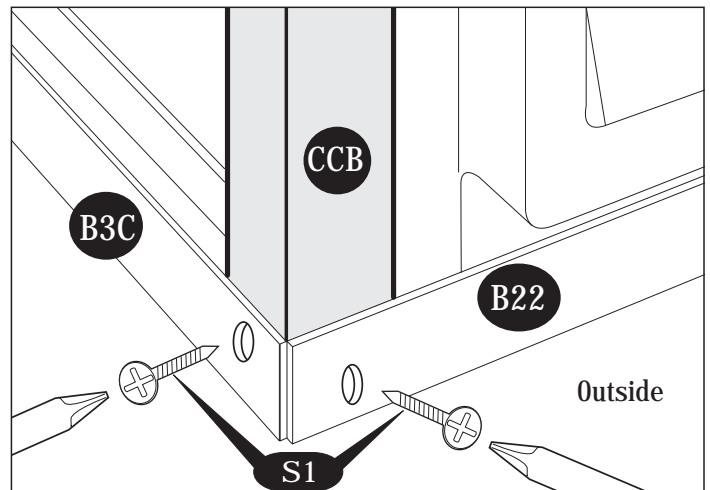

12. Stabilize the side panels with center bands (CB3LC) & (CB3SC). Fix (FCB) fitting to corner column (CCB).
See Fig.1
Follow the Fig. 2, 3, 4 & 5.

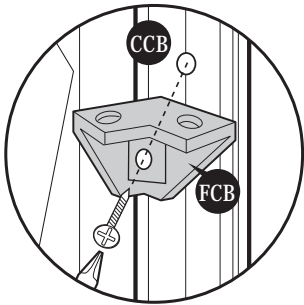
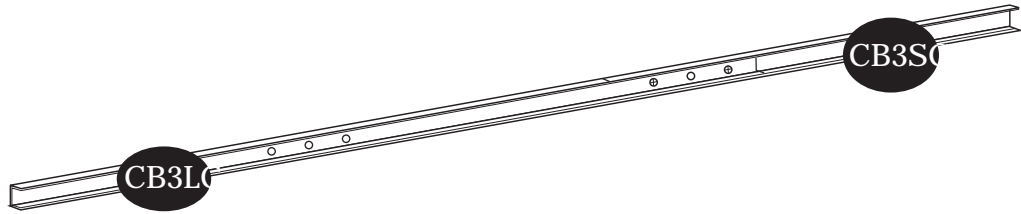

Fig.1: Use (S2) screws. Fix (FCB) fitting to (CCB). Leave it loose.

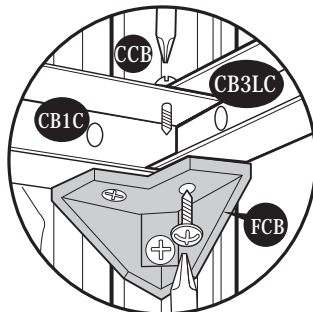

Fig.2: Use (S1) screws. Fix (CB3LC) to (FCB) and (CB1C)

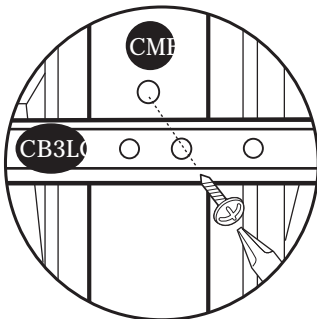
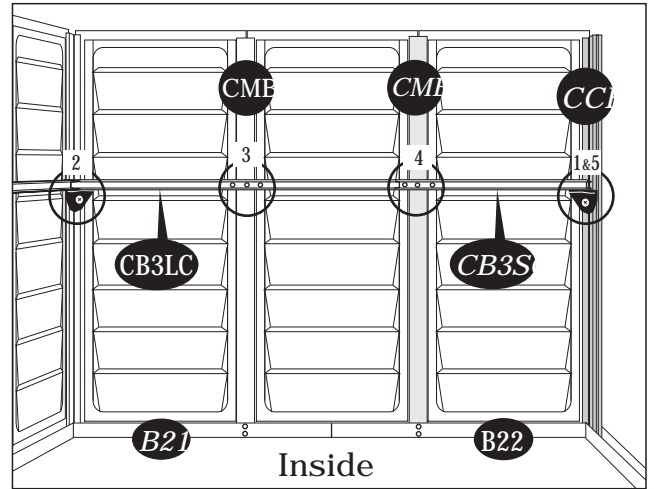

Fig.3: Use (S1) screws. Fix (CB3LC) to (CMB) columns.

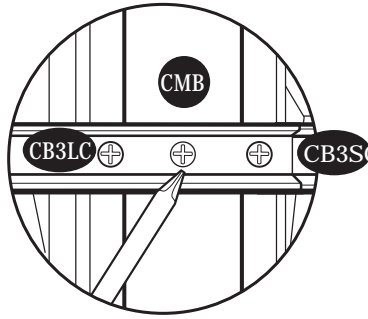

Fig.4: Fix to (CMB) with (S1) screw.

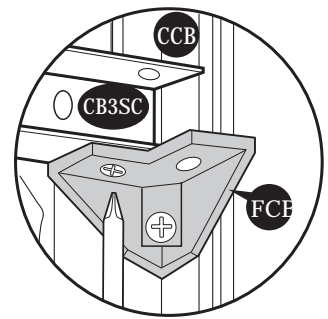
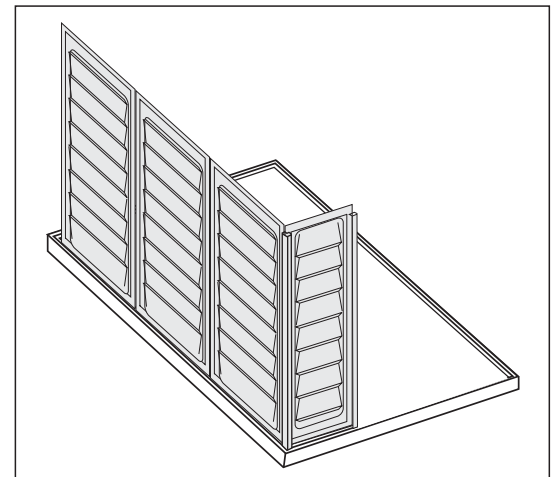
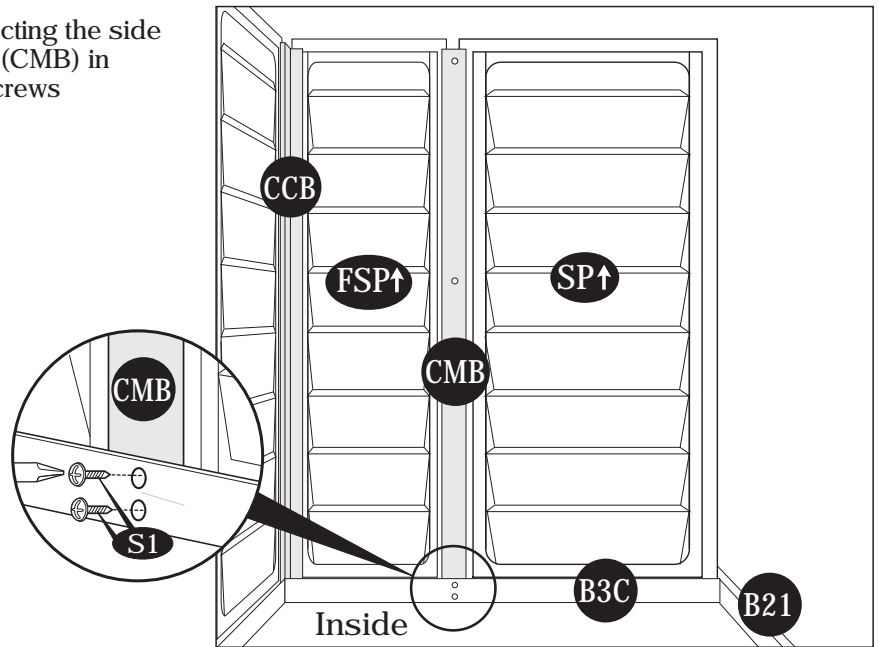

Fig.5: Use (S1) Screws. Fix (CB3SC) to (FCB) fitting.



13. Working from inside continue connecting the side panels (FSP↑) and (SP↑) with columns (CMB) in sequence along (B3C) base. Use (S1) screws to fix columns to base.



14. Slide corner column (CCC) into the side panel (SP↑) pushing the column into position.

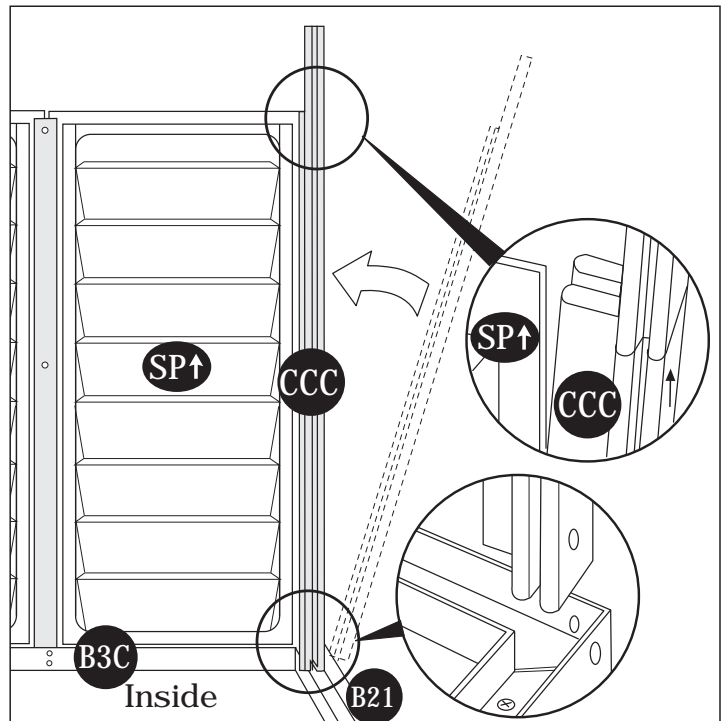

15. Working from outside use (S1) screws to secure the corner column (CCC) to bases (B3C) and (B21).

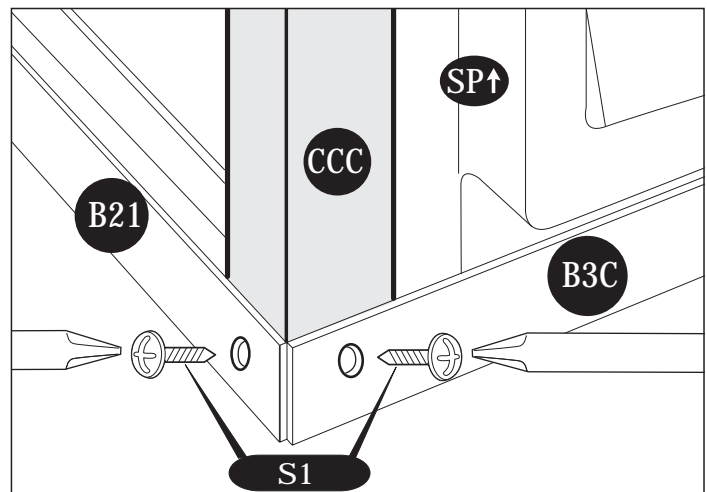

16. Stabilize the side panels with center band (CB2C).
 Fix (FCB) to column (CCC).
 See (fig.1) (fig.2) (fig.3) and (fig.4) for details.

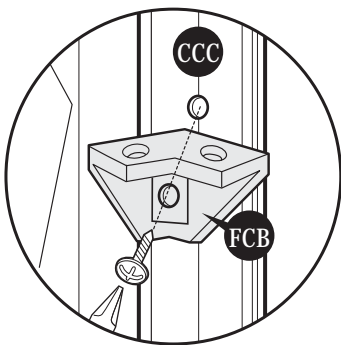
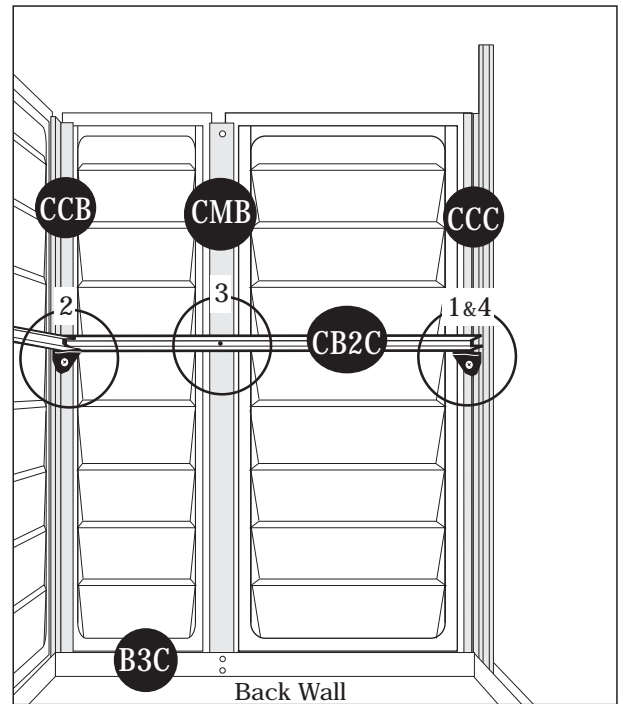

Fig. 1: Use (S2) screw. Fix (FCB) to (CCC). Leave it loose.

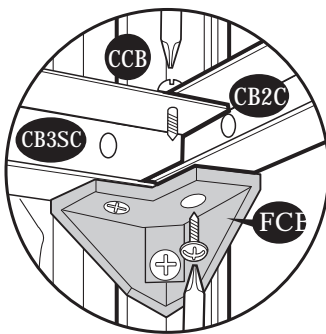

Fig. 2: Use (S1) screws. Fix (CB2C) to (FCB) and (CB3SC).

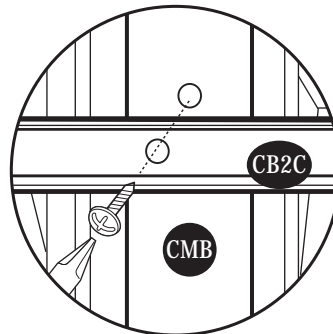

Fig. 3: Use (S1) screws. Fix (CB2C) to (CMB) column.

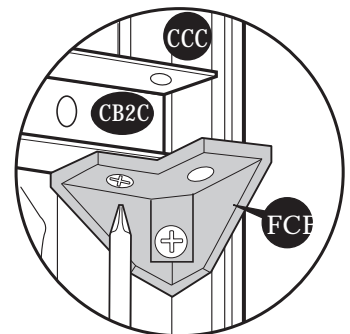
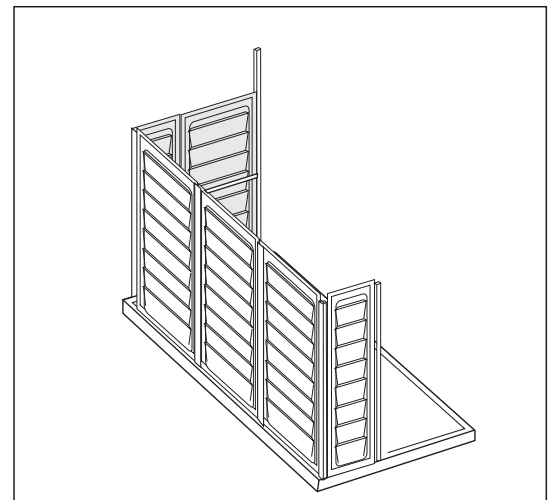
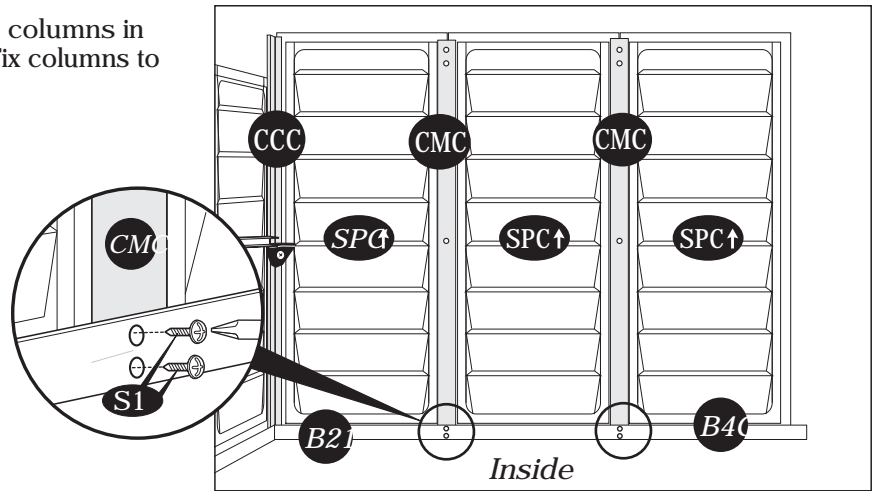

Fig. 4: Use (S1) screw. Fix (CB2C) to (FCB).



17. Continue connecting the panels and columns in sequence along base (B21) and (B4C). Fix columns to base with (S1) screws.



18. Fix door column (CDRC) to last panel and base.

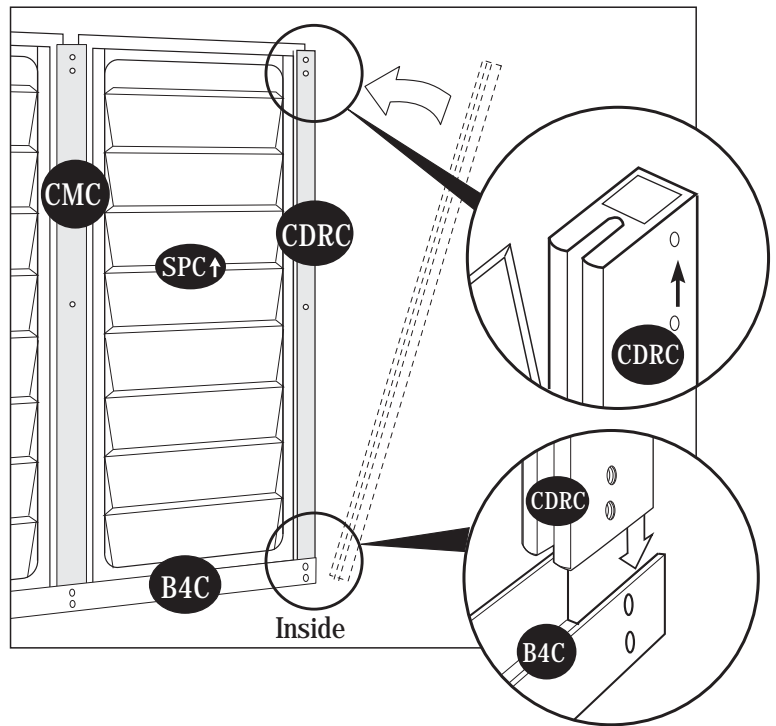

19. Working from inside use (S1) screws to secure the door column (CDRC) to base (B4C).

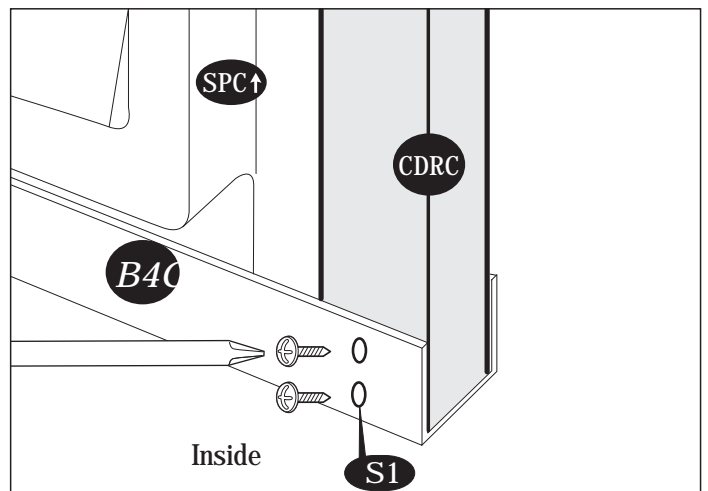

20. Stabilize the side panels with center bands (CB5C) & (CB3SC).
Follow the Fig. 1, 2, 3, 4 & 5.

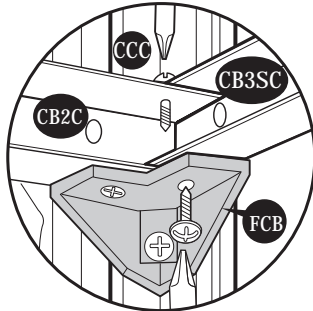
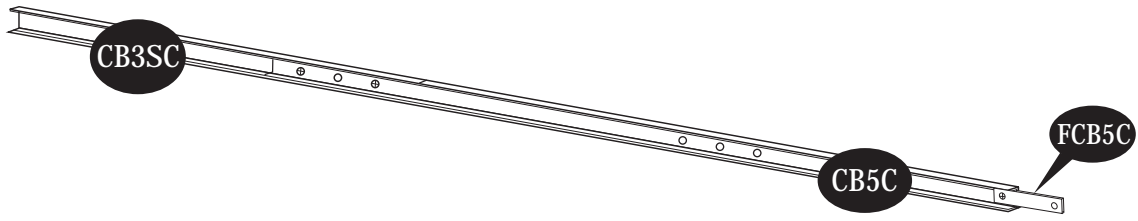

Fig.1: Use (S1) screws. Fix (CB2C) to (FCB) and (CB3SC)

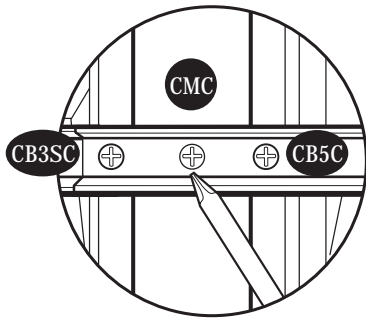
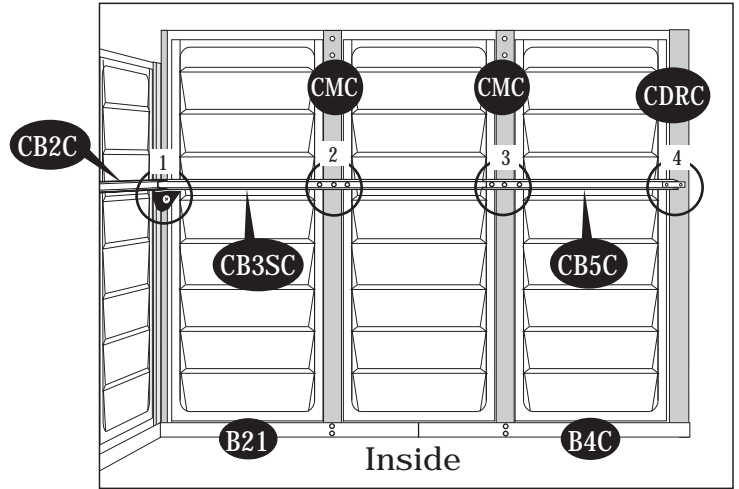

Fig.2: Fix to (CMC) with (S1) screw.

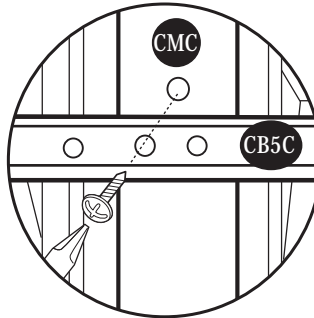

Fig.3: Use (S1) screws. Fix (CB5C) to (CMC) columns.

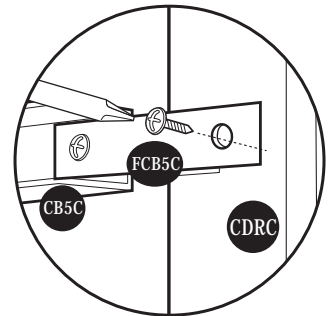

Fig.4: Use (S1) screw. Fix (FCB5C) to (CDRC).

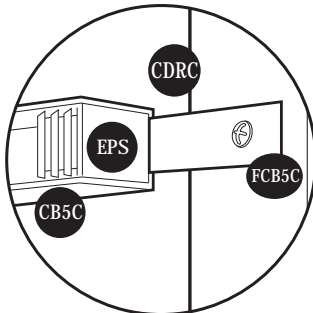
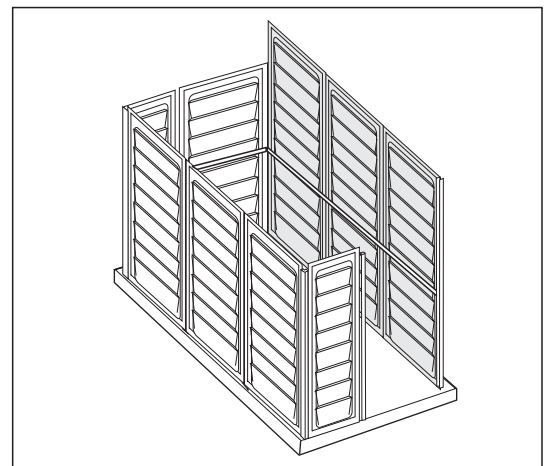

Fig.5: Fix the (EPS) at the end of (CB5C).



Note After completing the center band assembly fully tighten the three center band fittings (FCB) to the corner column (CCB) & (CCC).



C. Roof Frame



Parts Needed:

(2) RS1 Roof Structure	(RS1C)	(1) Door Stopper Horizontal	(DSHC)
(1) RS2 Front Roof Structure	(RS2FC)	(1) Door Column Fitting Left	(FDCLC)
(1) RS2 Back Roof Structure	(RS2BC)	(2) Corner Column Fitting	(FCC)
(1) RS3 Roof Structure Long	(RS3LC)	(3) Middle Column Fitting	(FMC)
(1) RS3 Roof Structure Short	(RS3SC)	(2) 90 Degree Joint	(RJ)
(2) RS4 Roof Structure	(RS4C)	(2) 'L' Bracket	(FRLC)
(2) RS5 Roof Structure	(RS5C)	(4) Roof Structure Fitting	(FMRC)
(2) RS6 Roof Structure	(RS6C)	(1) 'T' Bracket	(FRTC)
(2) RS8 Roof Structure Support Long	(RS8C)		
(2) RS9 Roof Structure Support Short	(RS9C)		

1. Insert the middle column fitting (FMC) into top of middle columns (CMB) square tubing inserts. Fix the column fittings (FMC) to columns (CMB) with (S1) screws.

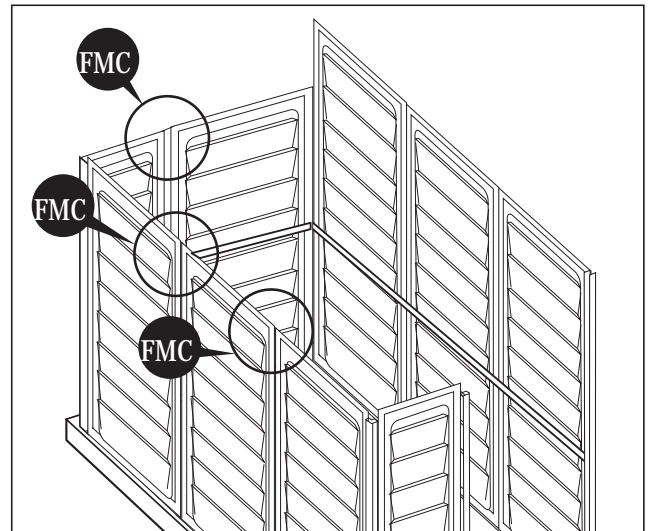
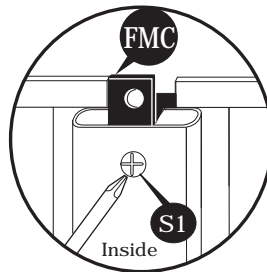
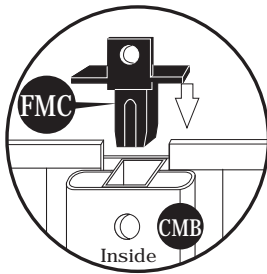

2. Insert the corner column fittings (FCC) into the corner column's (CCB) insert square tubing. Fix (FCC) to (CCB) with (S1) screws.

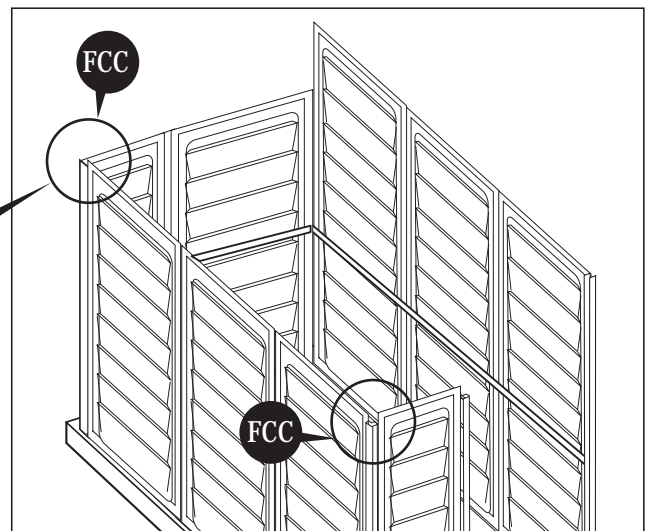
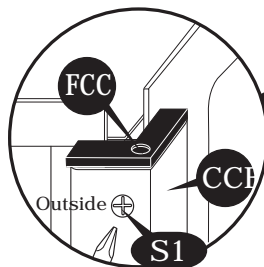
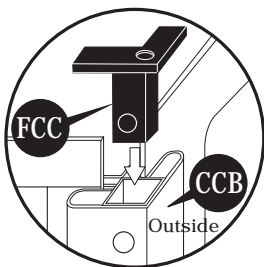

3. Insert the door column fitting (FDCLC) into the door column (CDLC) square tubing inserts.

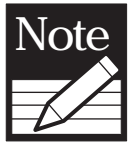

Do not fix any screws in this position

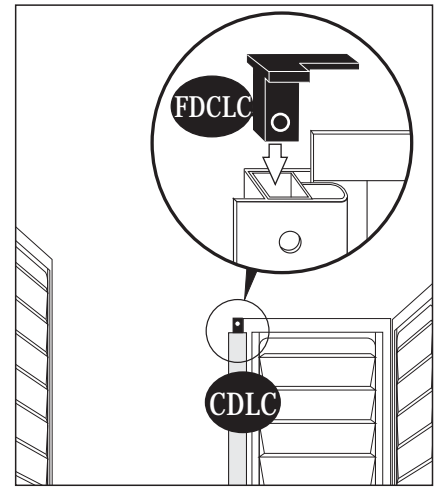
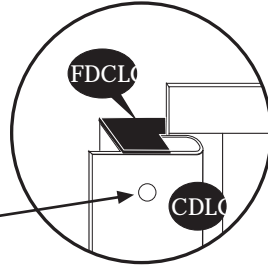

4. Fix the roof structure fitting (FMRC) to middle column (CMC) with (S1) screws through the middle hole. See (Fig.1).

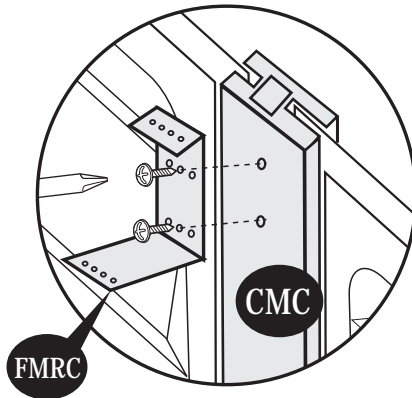
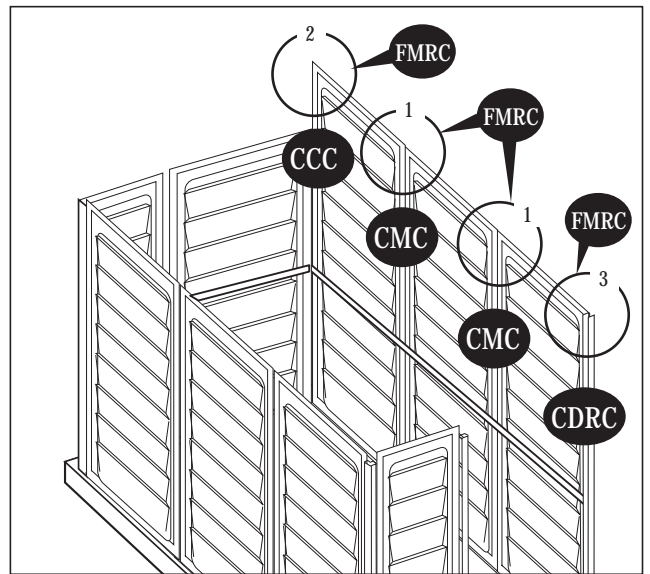

Fig.1



5. Fix the roof structure fitting (FMRC) to corner column (CCC) with (S1) screws through the left hole. See (Fig.2).

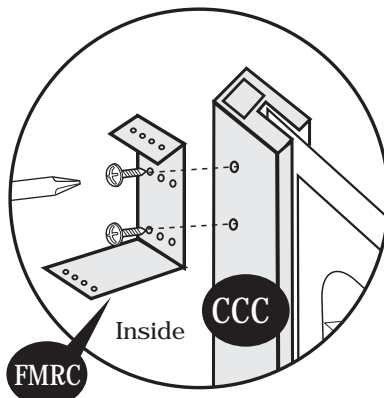

Fig.2

6. Fix the roof structure fitting (FMRC) to door column (CDRC) with (S1) screws through the right hole. See (Fig.3).

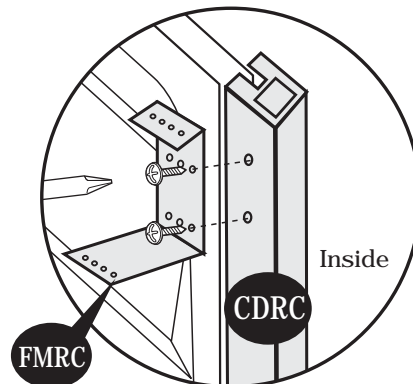
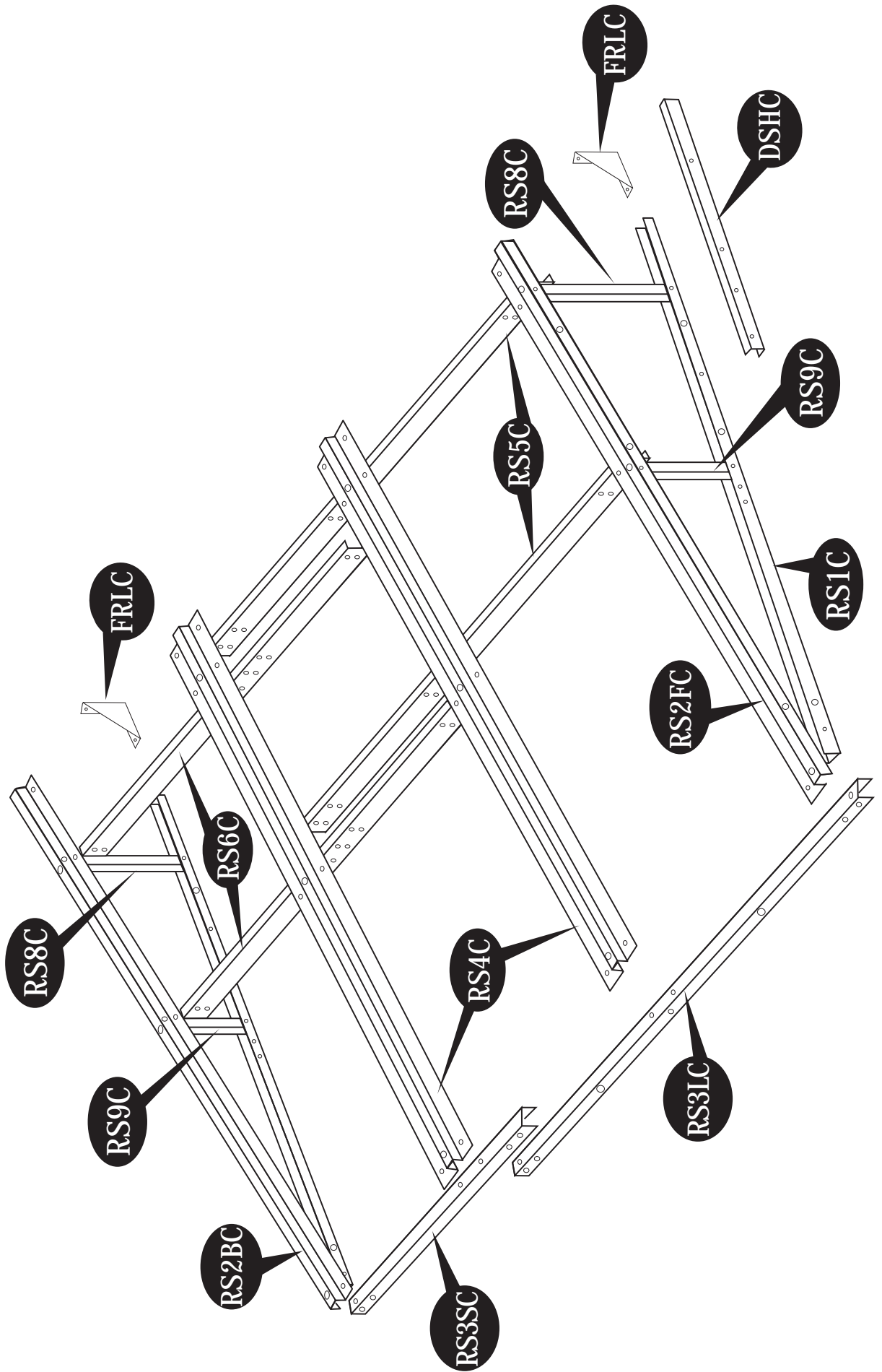

Fig.3

ROOF STRUCTURE EXPLODED VIEW



Front roof structure assembly

7. Assemble the roof support (RS8C) & (RS9C) to (RS1C) with 2 (S1) screws. Fix (FRLC) to (RS1C) with 2 (S1) screws.

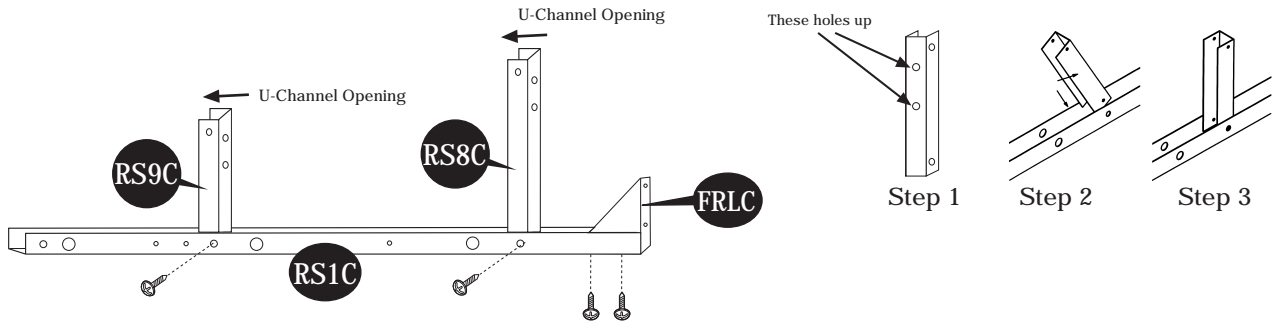

8. Assemble roof structure (RS2FC) to (RS8C) & (RS9C) with (S1) screws.

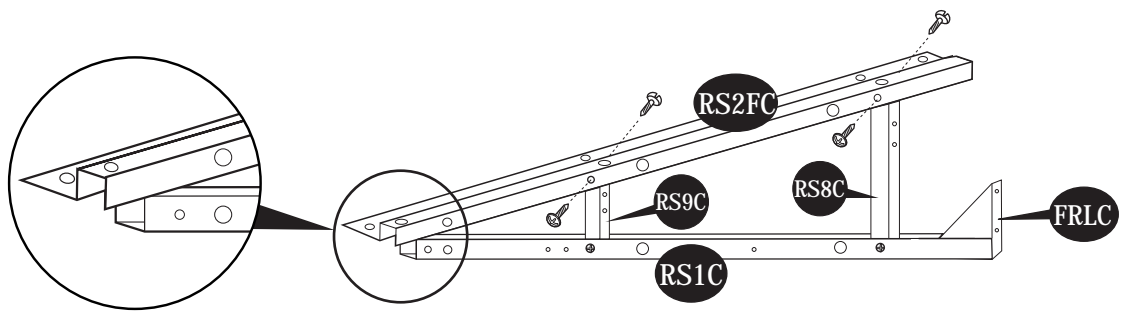

Back roof structure assembly

9. Assemble the roof support (RS8C) & (RS9C) to (RS1C) with 4 (S1) screws. Fix (FRLC) to (RS1C) with 2 (S1) screws.

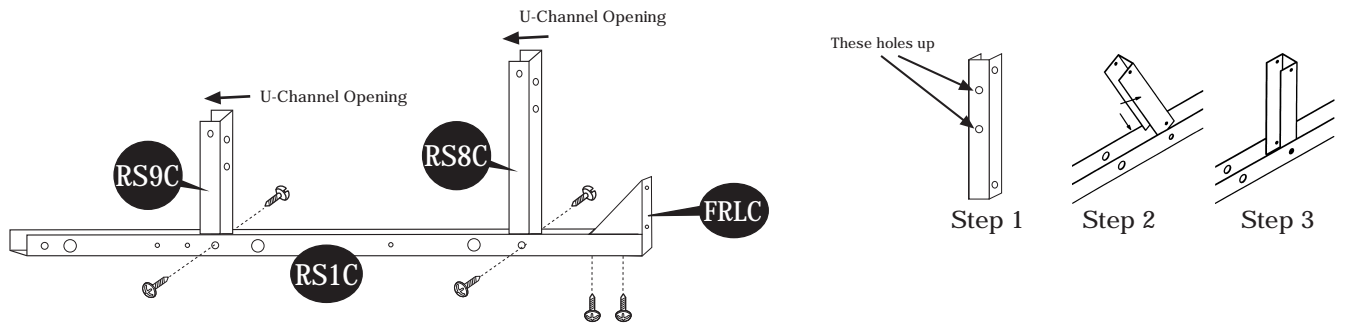

10. Assemble roof structure (RS2BC) to (RS8C) & (RS9C) with (S1) screws.

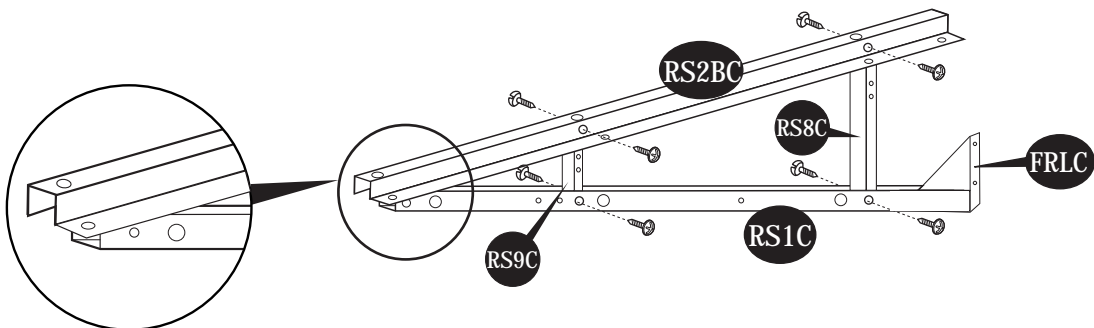

11. Assemble the roof structure (RS3LC) & (RS3SC) with (S1) screws. See fig.1.

11a. Insert 90 degree joint (RJ) into the (RS3LC) U-channel Roof support. Use a hammer to push in. Use (S1) screws to fix. Repeat on other end of (RS3SC). Use (S1) screws to assemble (RS3LC) & (RS3SC) together.

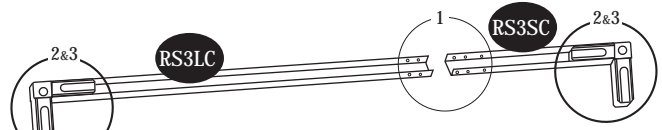

Note Refer Page No. 5 for overlapping method of (RS3LC) & (RS3SC).

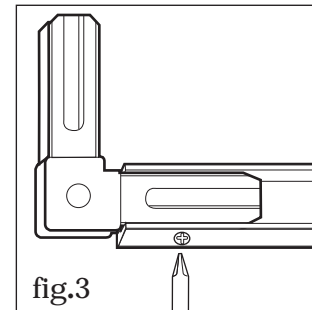
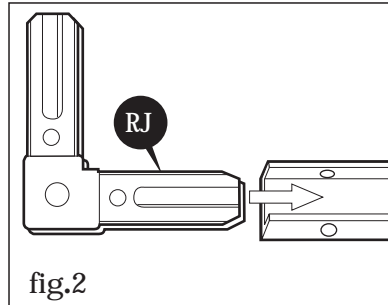
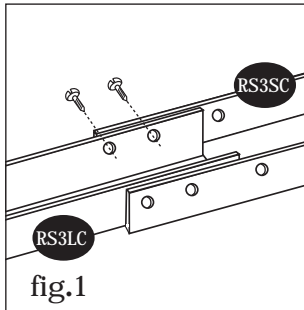

12. Assemble the roof structure (RS5C) into (RS6C) with 6 (S3) screws with nuts (2 sets).

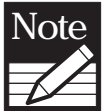
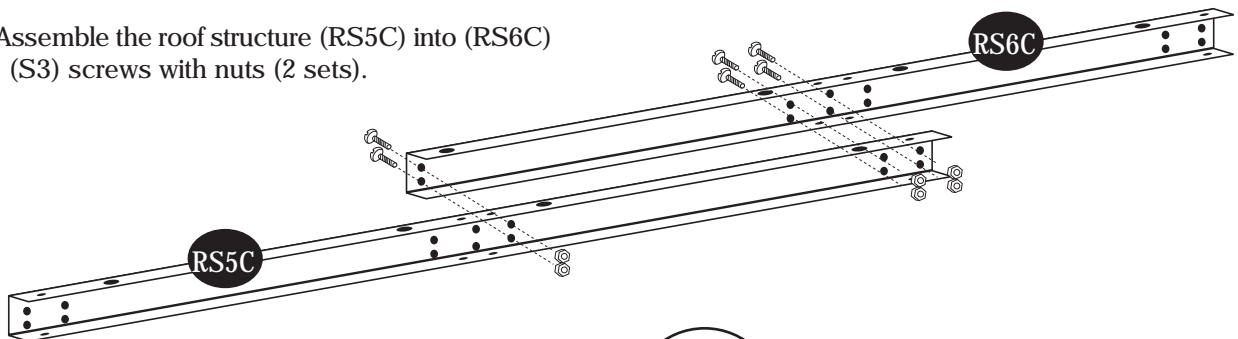

Note After assembly make sure (RS3LC) & (RS3SC) roof structure's U-Channel is positioned down.

13. Insert the roof supports (RS3LC) & (RS3SC) assembly into the U-channel of roof structures (RS1C). See (Fig.1). Follow (fig.2) & (fig.3)

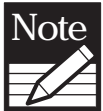

Note Notice the U-channel up position on roof structures (RS1C).

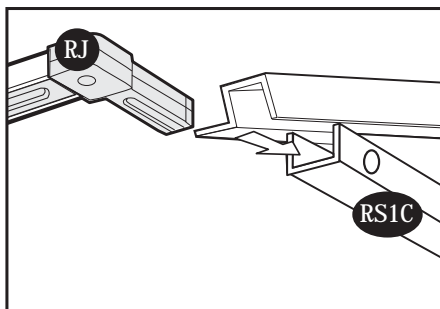
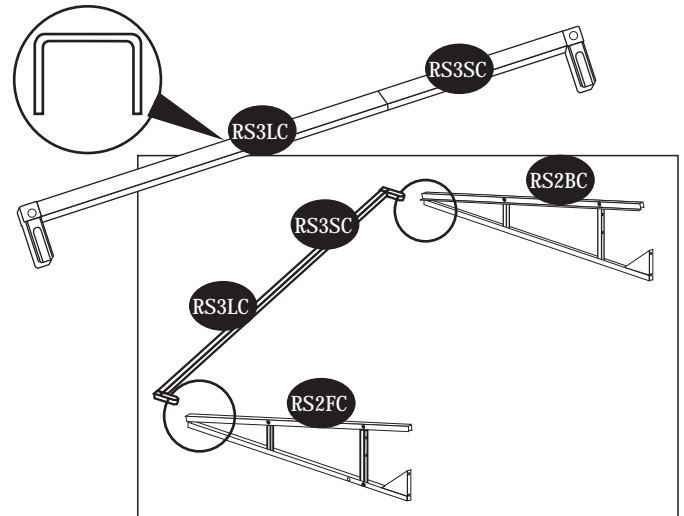
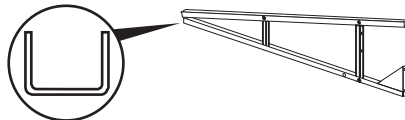

fig.1

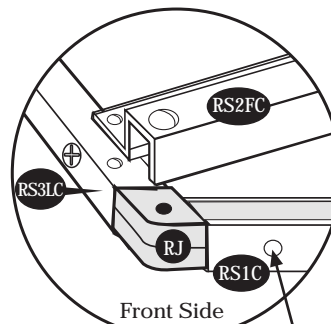

fig.2

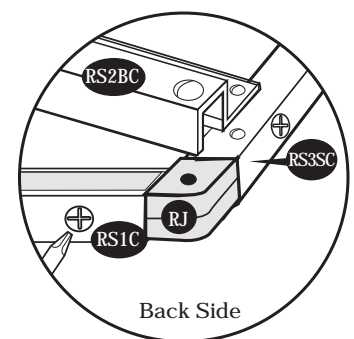
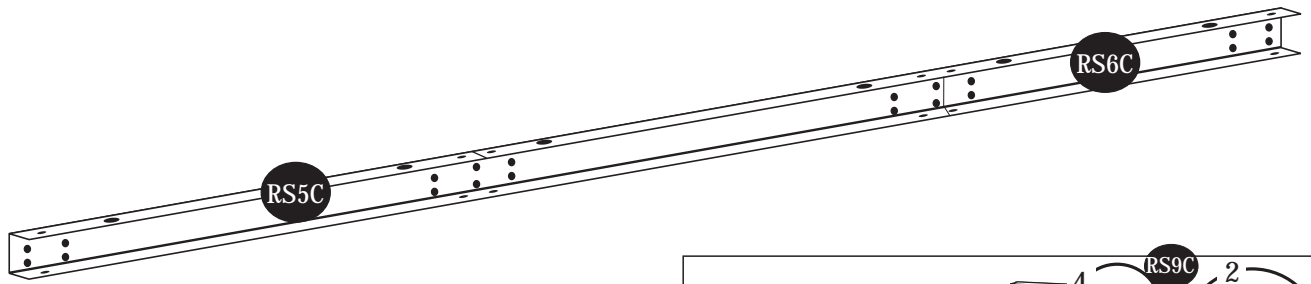

fig.3



Note Do not fix any screws in this position

Fix 90 degree joint (RJ) to (RS1C) with (S1) screw.



14. Place the roof structure assembly (RS5C) with (RS6C) into position on roof supports (RS8C).

Use (S1) screws to fix (RS5C) to (RS8C) & (RS2FC). See (Fig.1)

Use (S1) screws to fix (RS6C) to (RS8C) & (RS2BC). See (Fig.2)

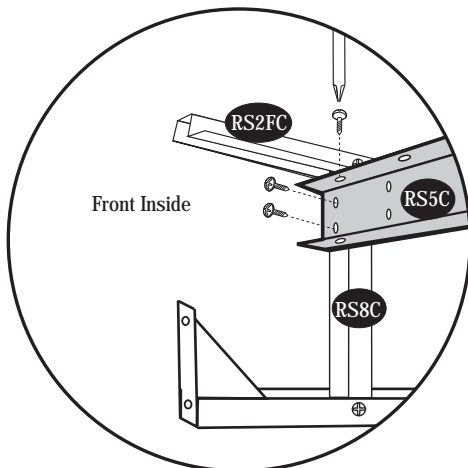
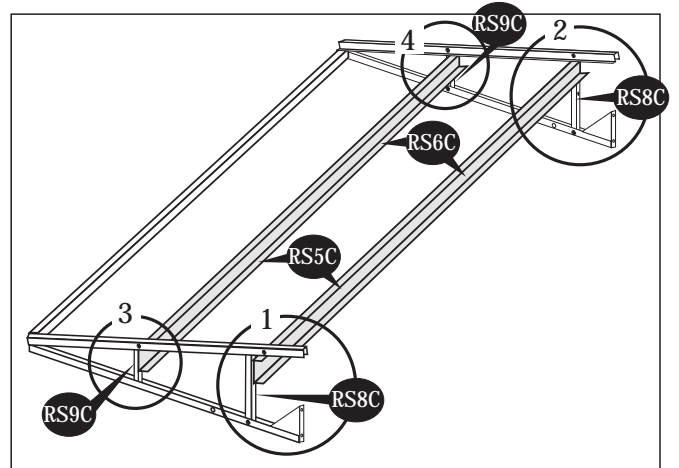

fig.1

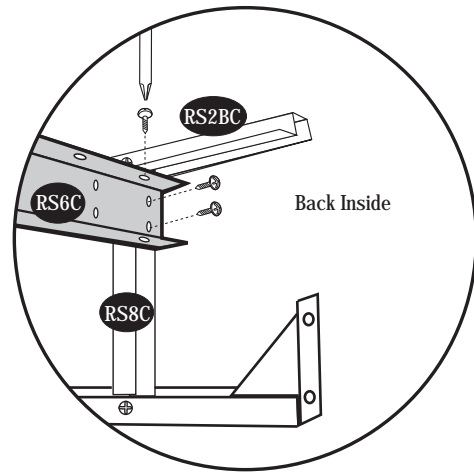

fig.2

15. Place the roof structure assembly (RS5C) with (RS6C) into position on roof supports (RS9C).

Use (S1) screws to fix (RS5C) to (RS9C) & (RS2FC). See (Fig.3)

Use (S1) screws to fix (RS6C) to (RS9C) & (RS2BC). See (Fig.4)

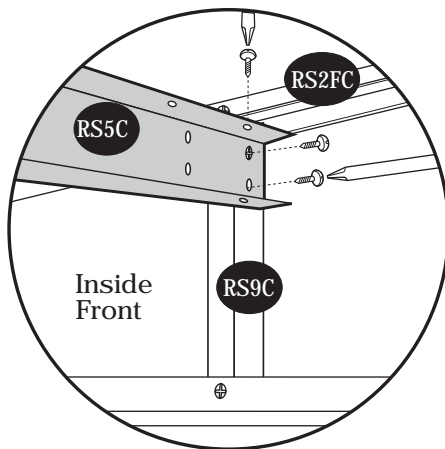

fig.3

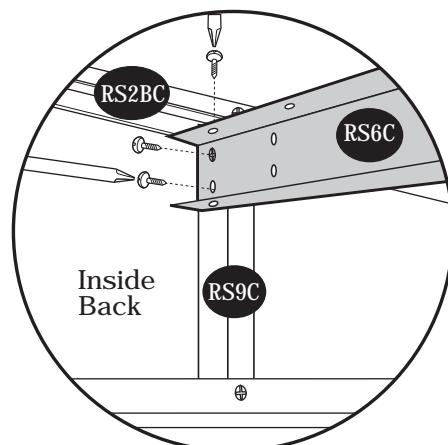

fig.4

16. Attach the roof structures (RS4C) to (RS3LC) and (RS3SC). See (fig.1)
 Attach the roof structures (RS4C) to (RS5C) and (RS6C). See (fig.2) & (fig.3)

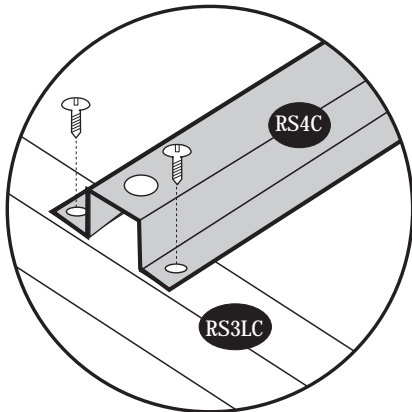
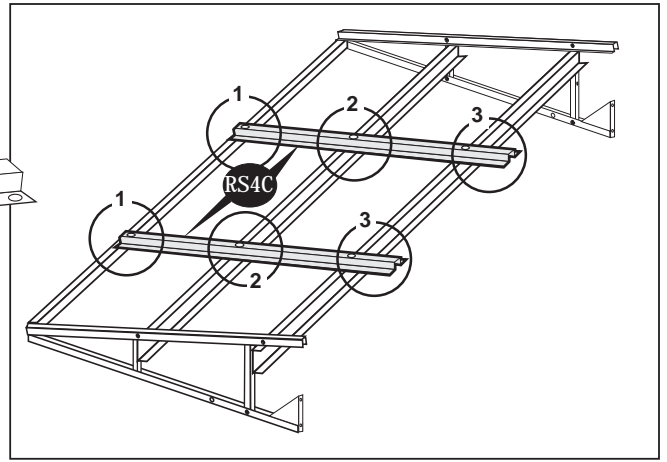
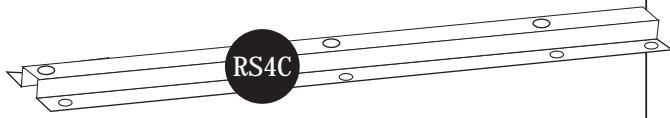

fig.1

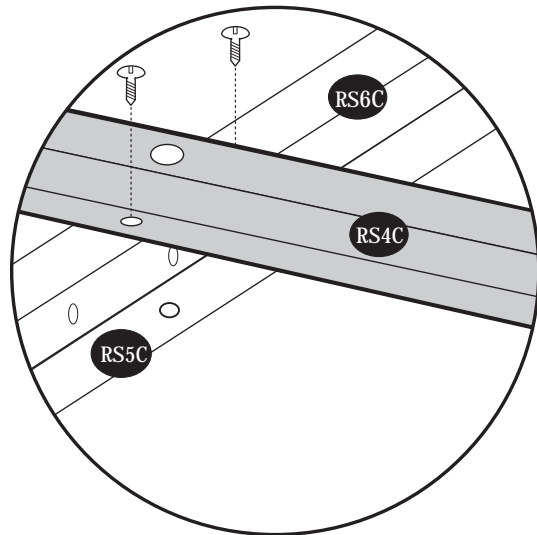

fig.2

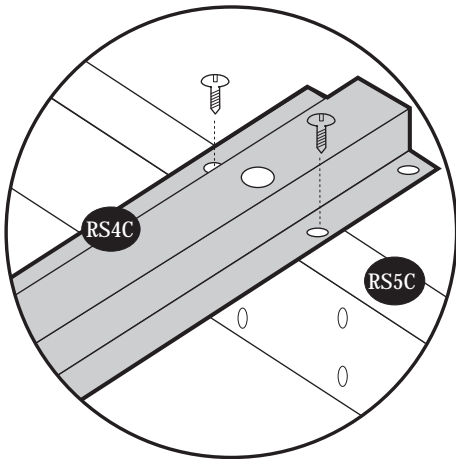
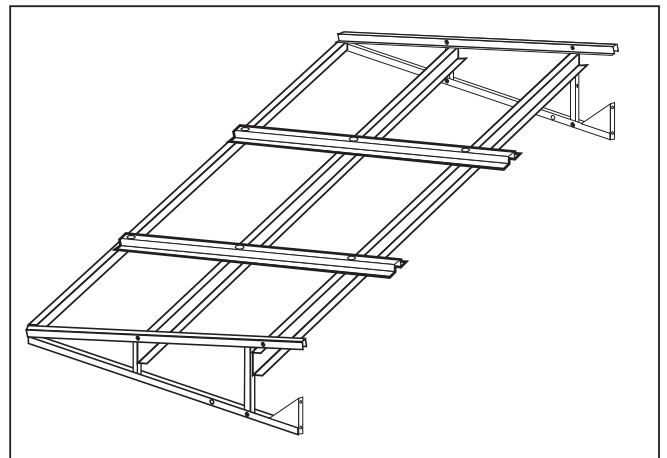
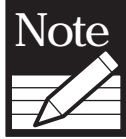
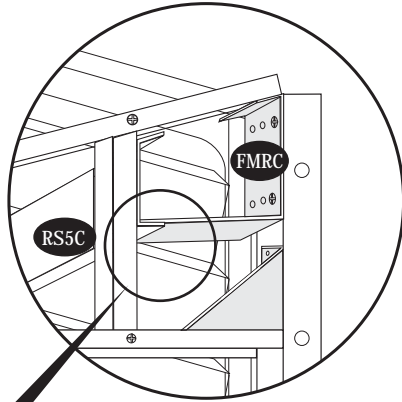

fig.3



17. Lift the roof structure assembly and place it on top of the columns and secure it.
Follow (fig.1) & (fig.2)



Note Make sure the roof structure fitting (FMRC) slides inside the (RS5C) & (RS6C).

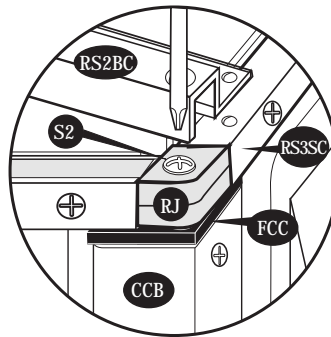
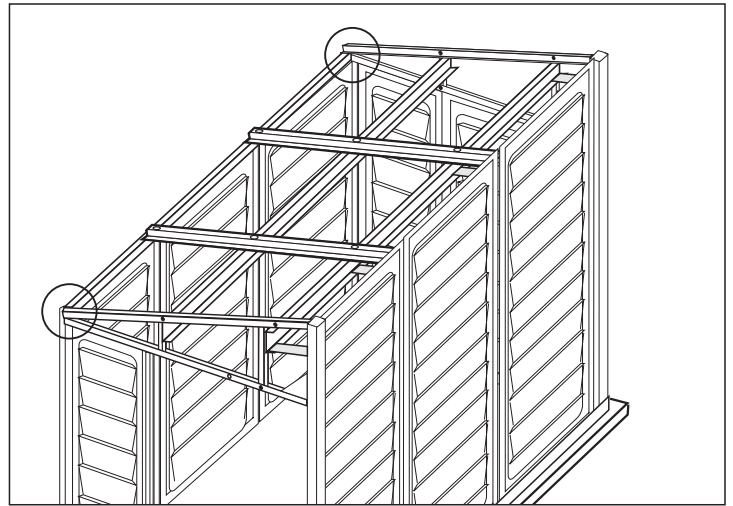

fig.1

Secure (RJ) with (FCC) using (S2) screw on both the corner columns.

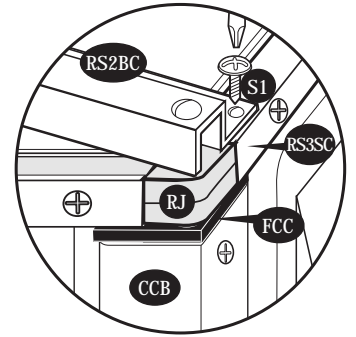

fig.2

Fix (RS2FC) & (RS2BC) to 90 degree joint (RJ) through (RS3LC) & (RS3SC) with (S1) screw.

18. Fix the (RS3SC), (RS3LC) & (RS1C) to (FMC) middle column fittings with (S1) screws.

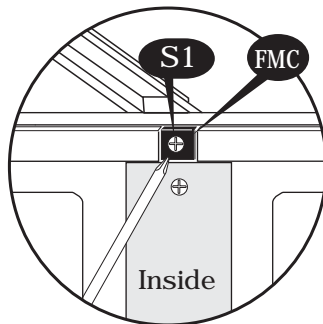

fig.1

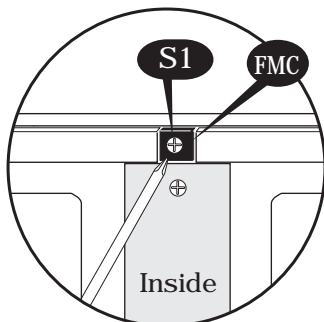
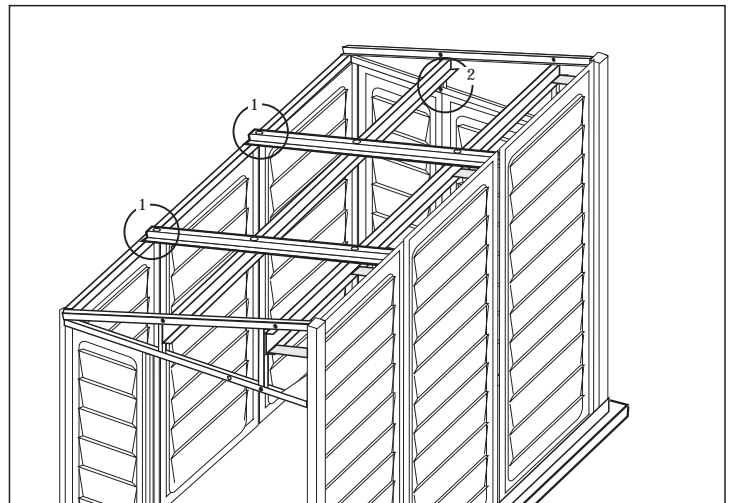

fig.2



19. Fix 'L' bracket (FRLC) to the columns with (S1) screws. See (fig.1)

Fix (RS5C) & (RS6C) to the roof structure fitting (FMRC) with (S1) screws. See (fig.1) & (fig.2)

Fix (RS2FC), (RS2BC) & (RS4C) to the roof structure fitting (FMRC) with (S1) screws. See (fig.1) & (fig.2)

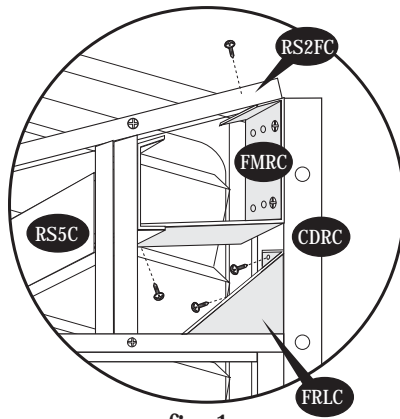
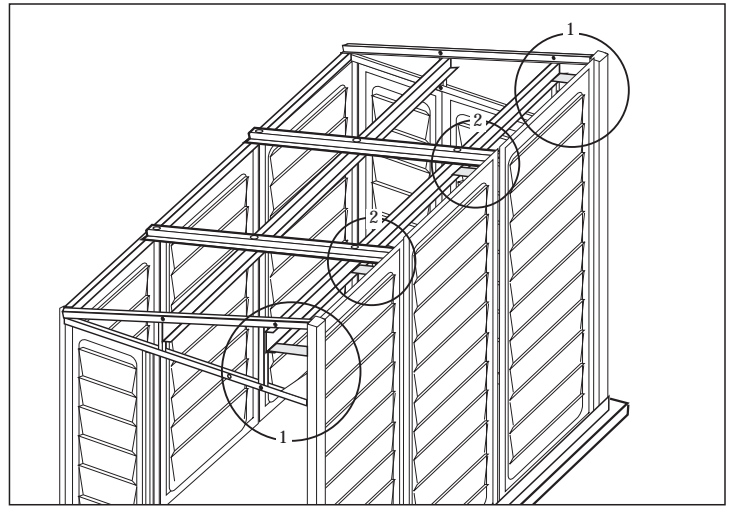

fig.1

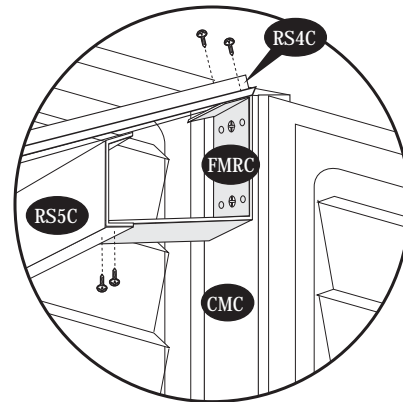
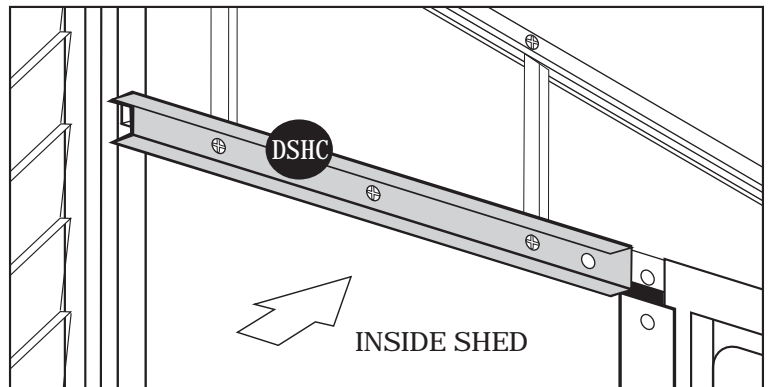
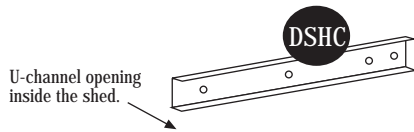
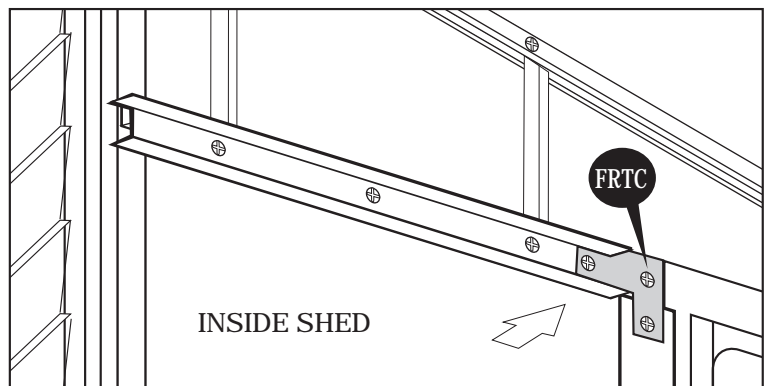
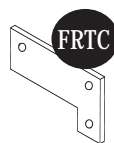

fig.2

20. Fix the door stopper horizontal (DSHC) to the front roof structure from inside with 3 (S1) screws.



21. Fix the 'T' bracket (FRTC) to (RS1C) with 3 (S1) screws.



22. Attach center band (CB6C) to door column (CDLC) and 90 degree joint (R.J).
See (fig.1), (fig.2) & (fig.3)

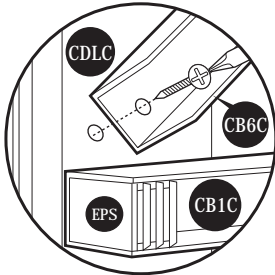

Fig.1: Use (S1) screw.
Fix (CB6C) to (CDLC)

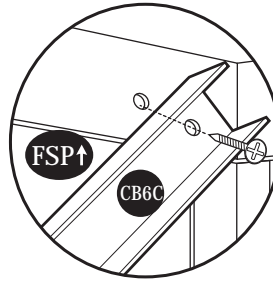

Fig.2: Use (S1) screw.
Fix (CB6C) to 90 degree joint (R.J)
through half side panel (FSP↑) and
(RS1C) roof structure.

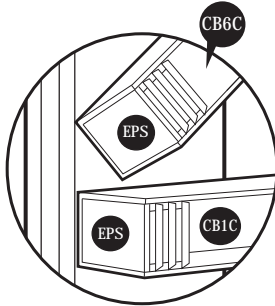
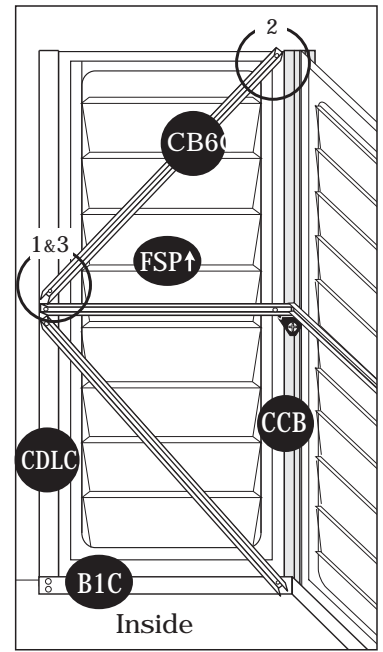

Fig.3: Fix the (EPS) at the end
of (CB6C).



D. Roof panels

Parts Needed:

- (3) Roof Panels (RP↑)
- (1) Facia Panel Left (FPLC)
- (1) Facia Panel Right (FPRC)
- (3) Ridge Cover (RRSC)
- (52) Roof Plug Washer (PWS)
- (52) Roof Plugs (PPG)
- (52) Roof Pins (PIN)
- (6) Sagging Support (RS14C)

1. First put the roof plug washer on the roof plug. See (fig.1) Place facia panel (FPLC) to front roof structure. Locate the holes in the facia panel through roof structure and fix with roof plug w/washers. See Step 1.

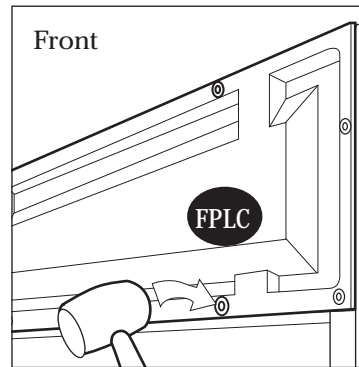

Step 1

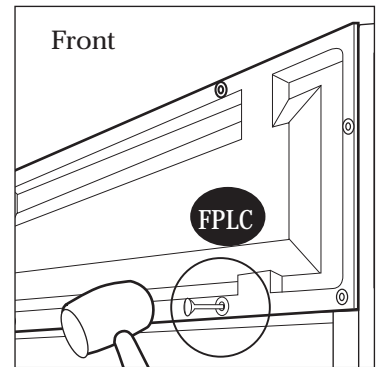

Step 2

2. Use a hammer to drive in roof pins (rubber mallet). See Step 2.

3. Repeat action to fix facia panel (FPRC) on backside. See Step 3 & 4.

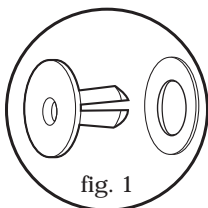

fig. 1

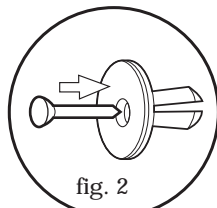
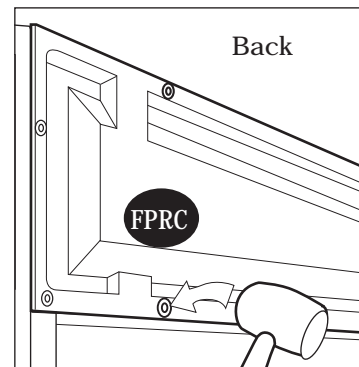
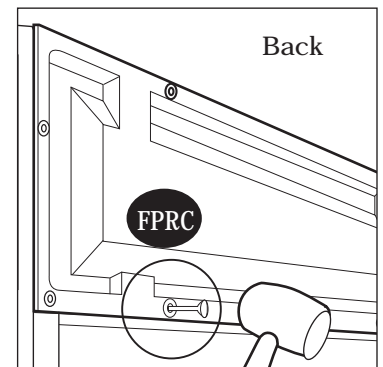

fig. 2



Step 3



Step 4

4. Start attaching the roof panels from (FPLC) front side by sliding the roof panel (RP↑) to roof structure. Locate the hole positions of the roof panel and roof structure. Fix roof plugs with washers. Use a hammer to drive in roof pins. See figures 1 thru 3.

5. Attaching the ridge cover (RRSC) on top of the roof panels (RP↑) start from the back side of the shed. See Fig.4 Fig.5 Fig.6

Note

Use a screw driver to align the holes.



Insert roof plugs into roof panels only as indicated.

Note

Do not insert Plugs at this point.

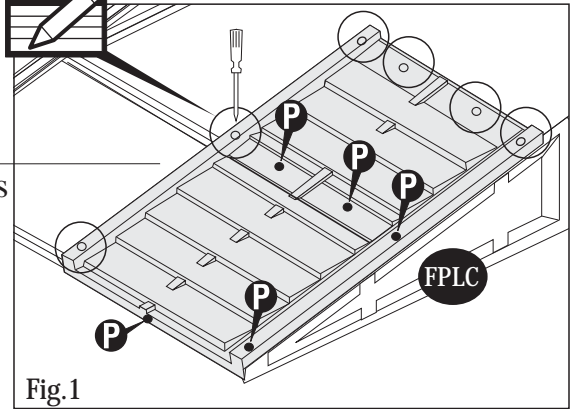

Fig.1

KEY

P Roof Plugs

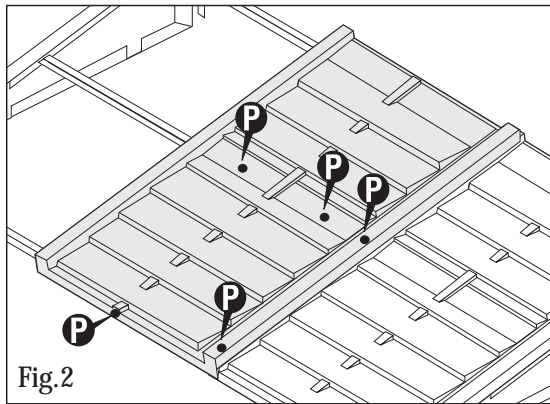

Fig.2

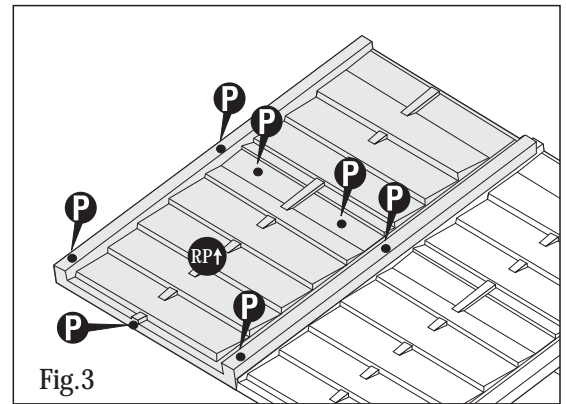

Fig.3

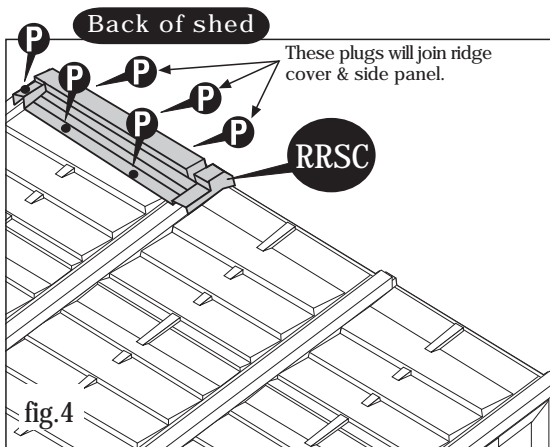

fig.4

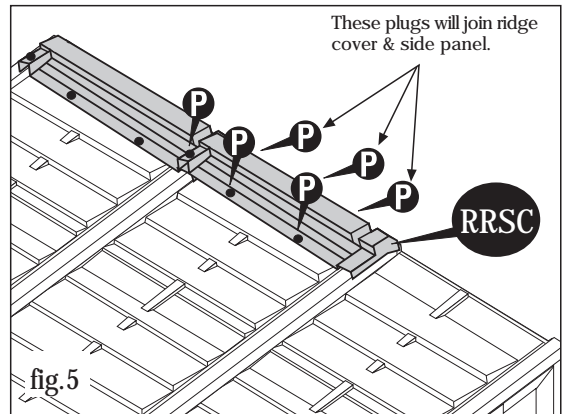

fig.5

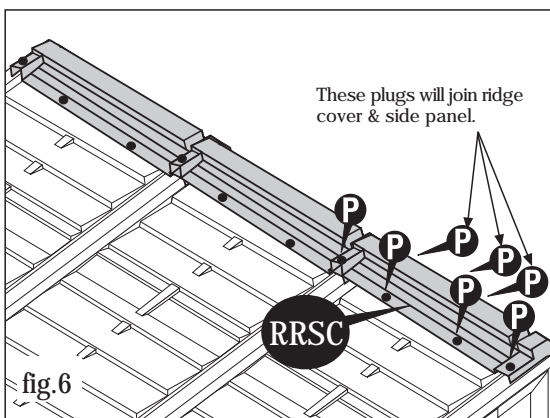
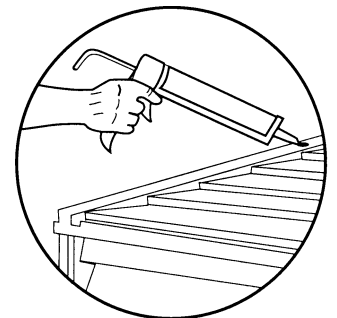

fig.6

Note

Finish the roof panels with a little silicone glue around the roof plugs.



6. Insert the sagging support (RS14C) from inside the shed by sliding it between roof support (RS5) and roof panel until it reaches (RS3) roof support for each panel. See fig.1.

7. Insert the sagging support (RS14C) from inside the shed by sliding it between roof support (RS5) and roof panel until it touches the other roof support. See fig.2.

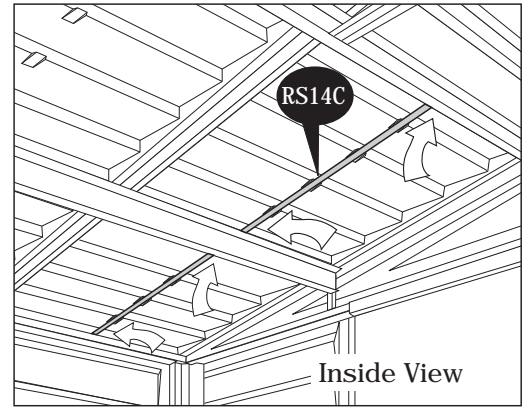
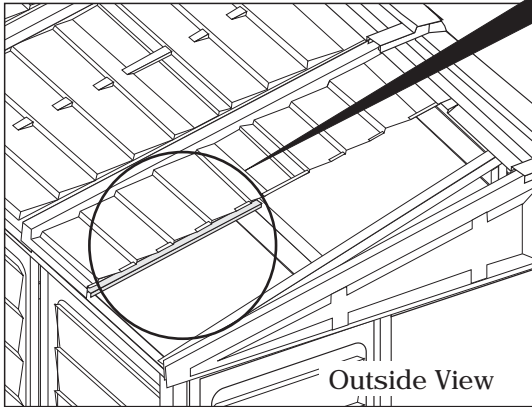
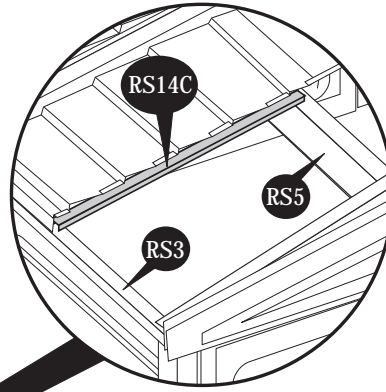

E. Doors

Parts Needed:

(1) Door

1. Attach the door (see fig.1) with Loose pin hinges on door column (CDRC).

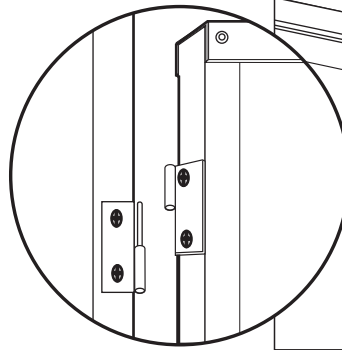
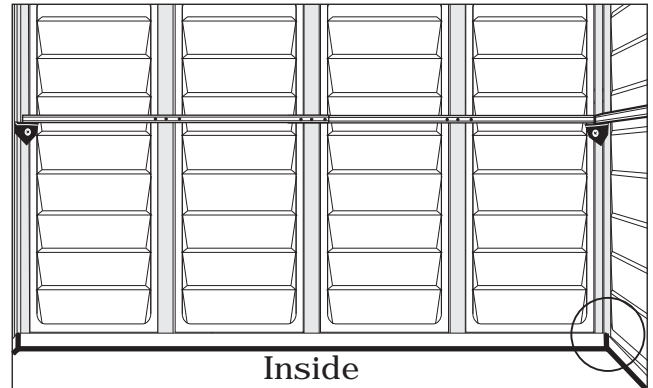
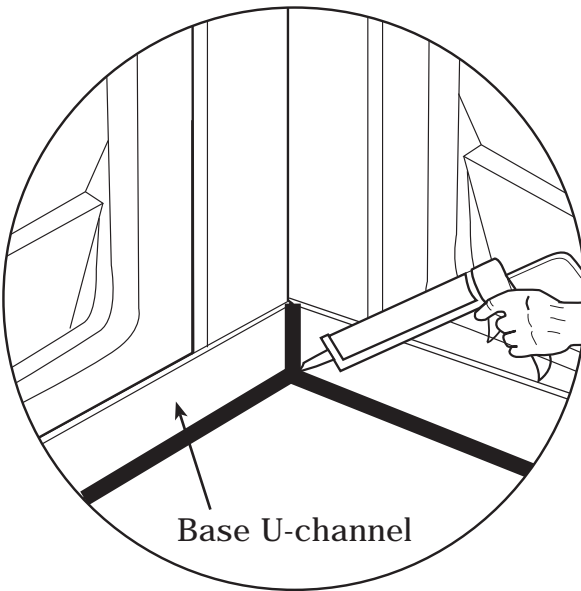

fig.1



Note: To prevent water leakage it is important that these instructions are followed.

1. After completing the assembly apply silicone around the perimeter of the base U-channel. Seal the corners, joints and base of door column also.



2. After completing the panel assembly, apply silicone around the roof plugs. This is optional and should be done for heavy rain areas if needed.

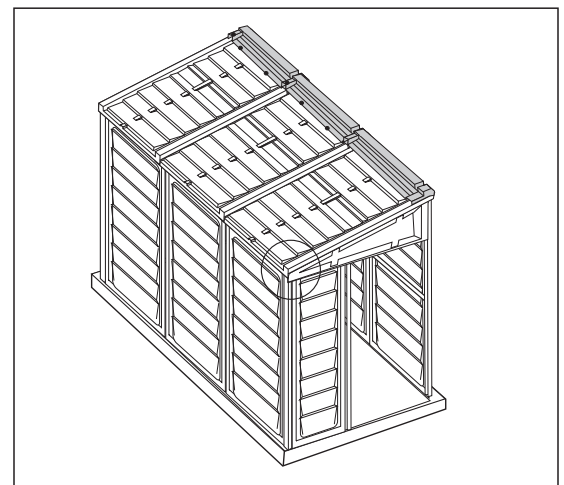
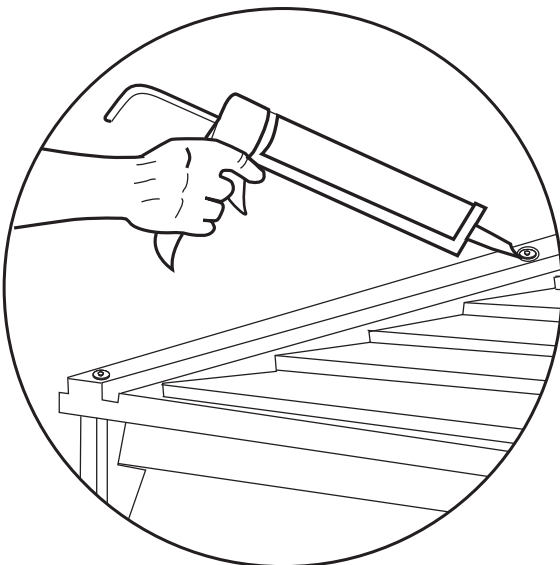

F. Optional Ventilation Kit

ACCESSORIES

CODE	DESCRIPTION	QTY
VC	VENTILATION COVER	2
VCP	VENTILATION COVER PIN	4

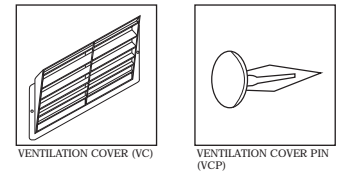

TOOLS YOU WILL NEED

Power Drill
 Dia 5/32" (4.2mm) drill bit
 Dia 1/2" (12.5mm) drill bit

Optional ventilation kits can be installed on any of the wall panels. However, we recommend mounting them on the top of the shed's back wall.

1. Place the ventilation cover (VC) as shown in fig.1. Using a pencil, mark the two side hole locations.
2. On the marked hole locations, drill out two holes using dia. 5/32" (4.2mm) drill bit as shown in fig.2. These holes will be used to attach the ventilation cover with the ventilation cover pins (VCP).
3. Use a dia. 1/2" (12.5mm) drill bit to drill out as many holes as desired behind the ventilation cover mounting area as in fig.3.
4. Attach the ventilation cover (VC) with the ventilation cover pin (VCP) as in fig.4.
5. Repeat the same to fix the second ventilation cover.

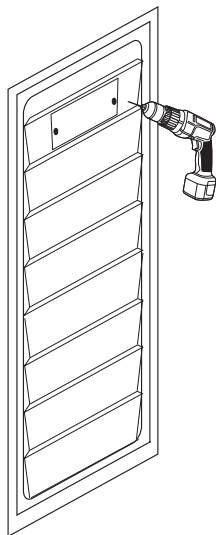
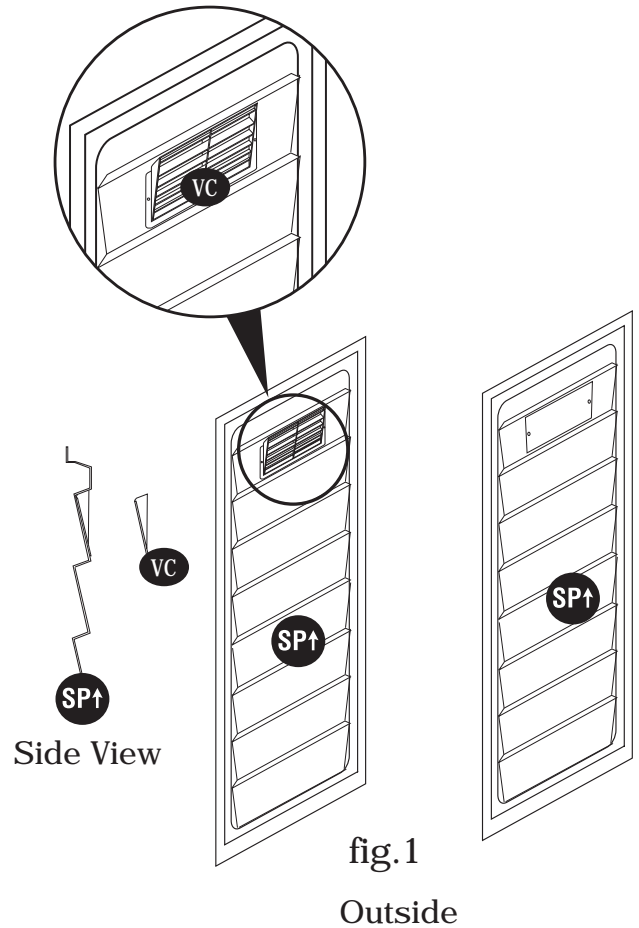

fig.2

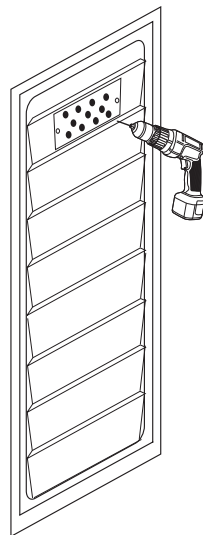

fig.3

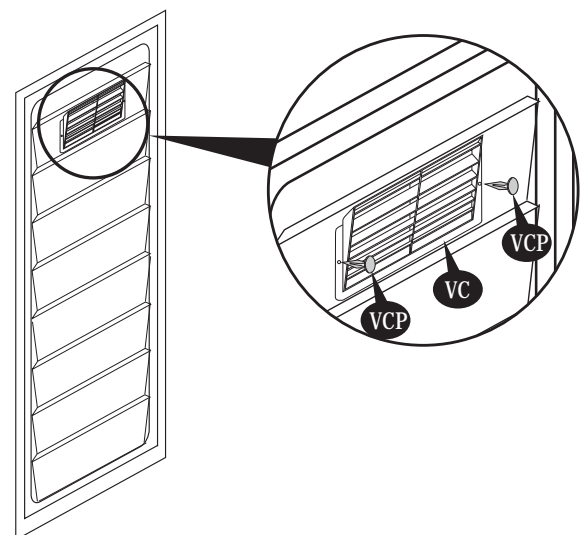

fig.4

High wind area installation instructions

Note: To ensure that your shed withstands high winds, you will need the following reinforcement.

Parts needed:

CODE	DESCRIPTION	QTY
S4	DIA. 4.2 x 16mm. (5/32" x 5/8") SHEET METAL SCREW	30 (not included with shed)
S5	M6 x 40mm. (1/4" x 1 1/2") Anchor bolt with nut	22 (not included with shed)

1. Shed or shed foundation should be placed on concrete footing by use of anchor bolt and nut. Using a carpenters square, line up corners. Align U-Channel base, mark the concrete at the holes in the base and drill concrete with 1/2" (dia. 12.5mm) concrete bit to accept anchor bolts to a 1 3/4" (44mm) depth. Replace base and secure with 1/4" x 1 1/2" (M6 x 40mm) anchor bolts. See fig.

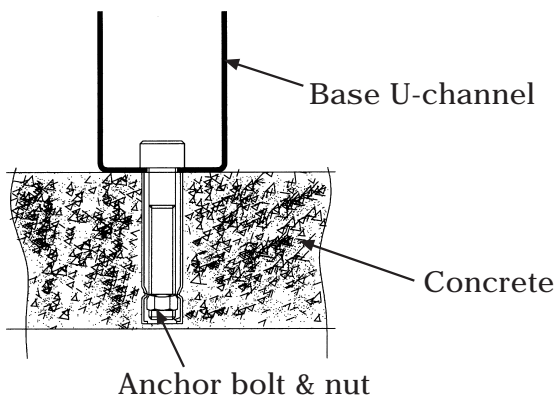
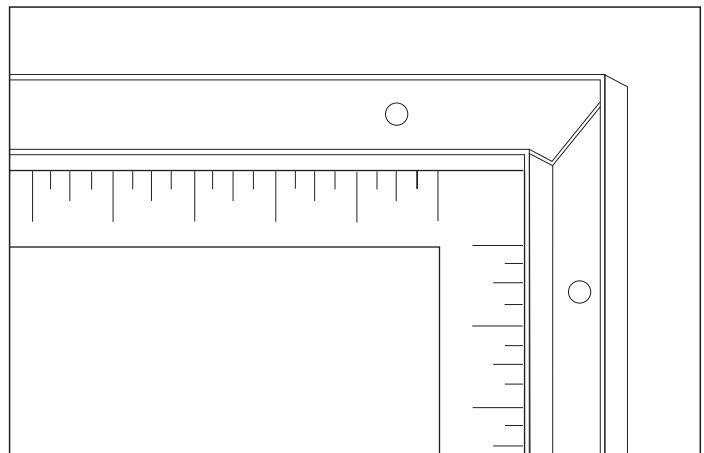

2. Attach each side panel (SP↑) on the bottom to the U-channel base. Using a dia. 3mm (1/8") drill with a power drill, make two equal distance holes on the U-channel base through the side panel. Drive a self tapping screw (S4) through the base U-channel to the side panel. Repeat this for every side panel. See blowup.

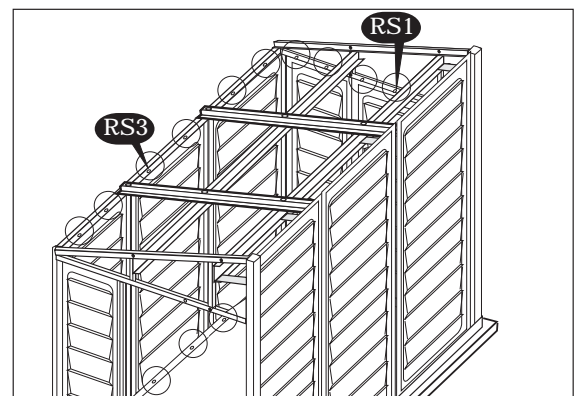
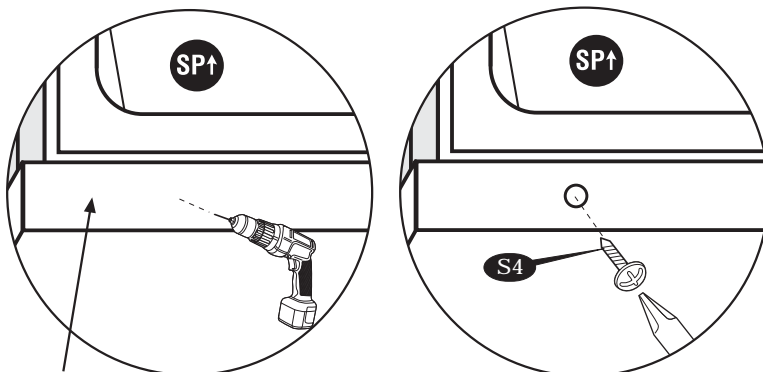

3. Attach each side panel (SP↑) on top to the roof structure (RS1) and (RS3). Using a dia. 3mm (1/8") drill with a power drill, make two equal distance holes on the side panel through the roof structure. Drive a self tapping screw (S4) through the side panel to the roof structure. Repeat this for every side panel. See blowup.

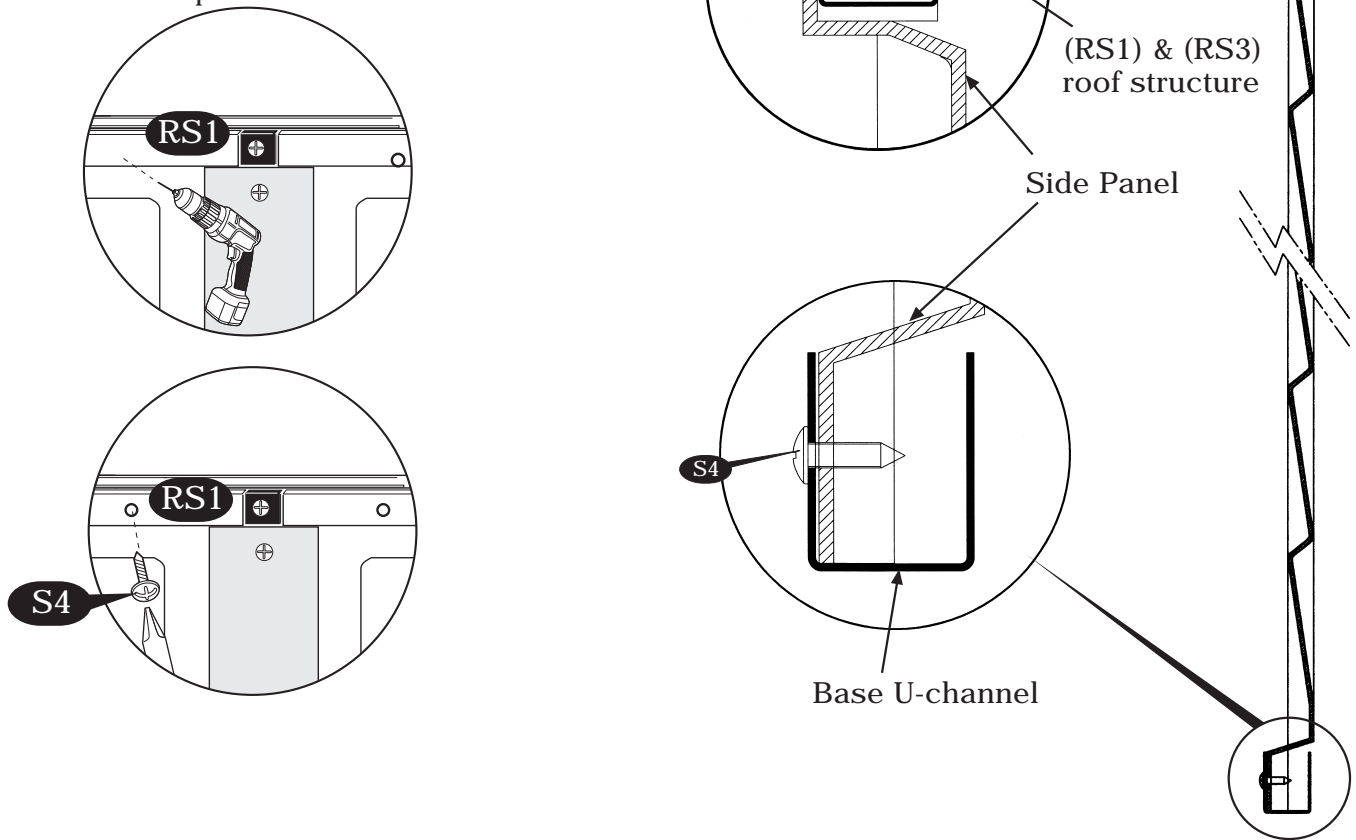

Important Warranty Information

The Duramax shed has been tested and passed wind loads of up to 115 mph in a controlled laboratory environment. Natural high wind areas create wind at unpredictable speeds that are very difficult to capture accurately by location. As such we cannot guarantee the performance of the shed in these extreme situations.

Foundation Kit

Instructions for Assembly Size 4' x 8'

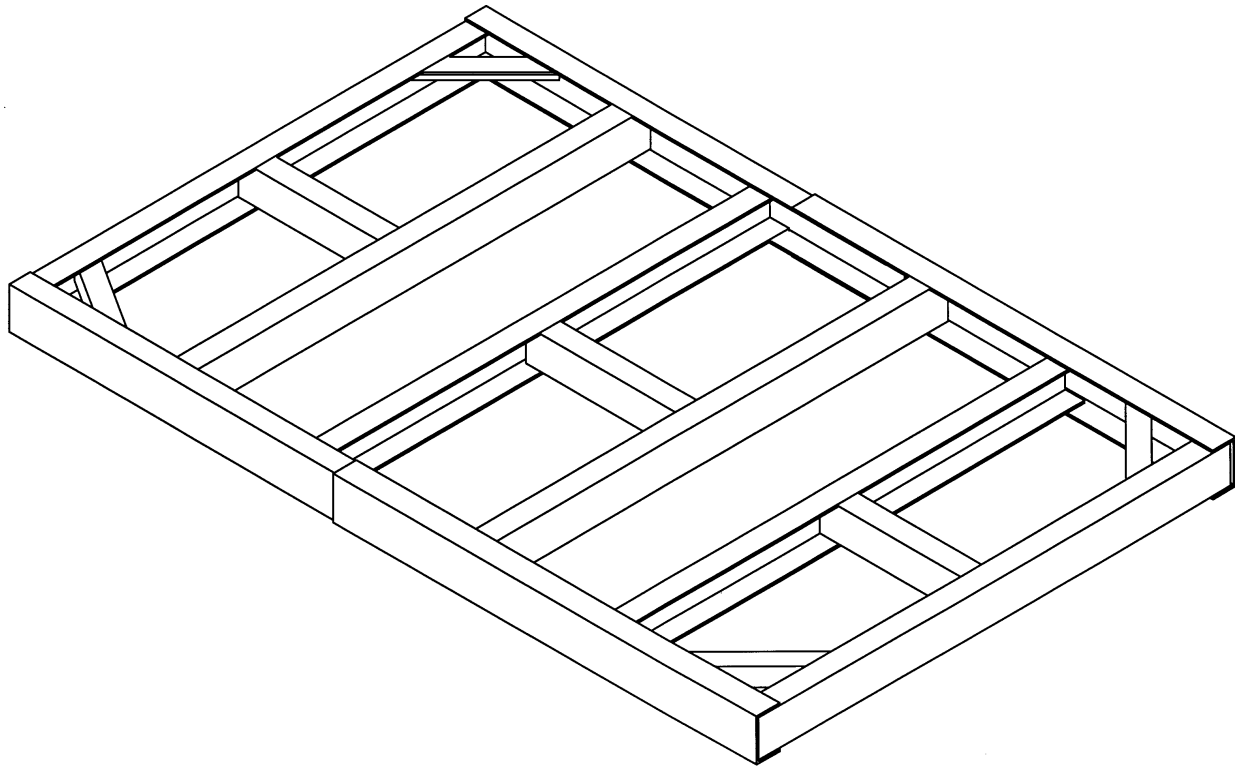

TOOLS YOU WILL NEED

- Cordless Drill - Philips Head

1. Assemble the channel (F04C) & (F05C) together using 4 screws. Make 2 sets.

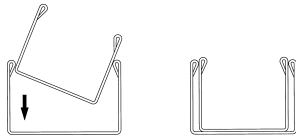
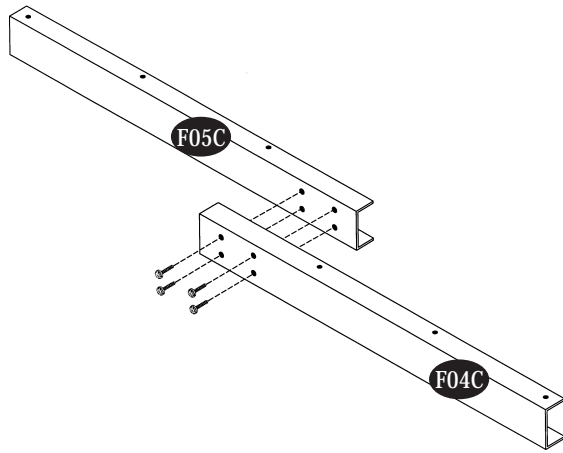

Parts List

Note: Check all parts prior to installation.

CODE	DESCRIPTION	QTY
F01C	FOUNDATION 'U' CHANNEL	6
F02C	FOUNDATION 'U' CHANNEL	3
F03	FOUNDATION 'L' ANGLE	4
F04C	FOUNDATION 'U' CHANNEL	2
F05C	FOUNDATION 'U' CHANNEL	2

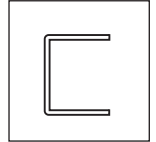

'U' CHANNEL

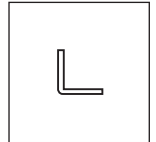

'L' ANGLE

ACCESSORIES

CODE	DESCRIPTION	QTY
S1	DIA. 4.2 x 16mm. (5/32" x 5/8") SHEET METAL SCREW	52

2. Make a frame with the sub assemblies as shown below.

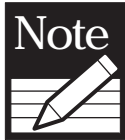

Note Make sure while assembling, the channel position should be as shown.

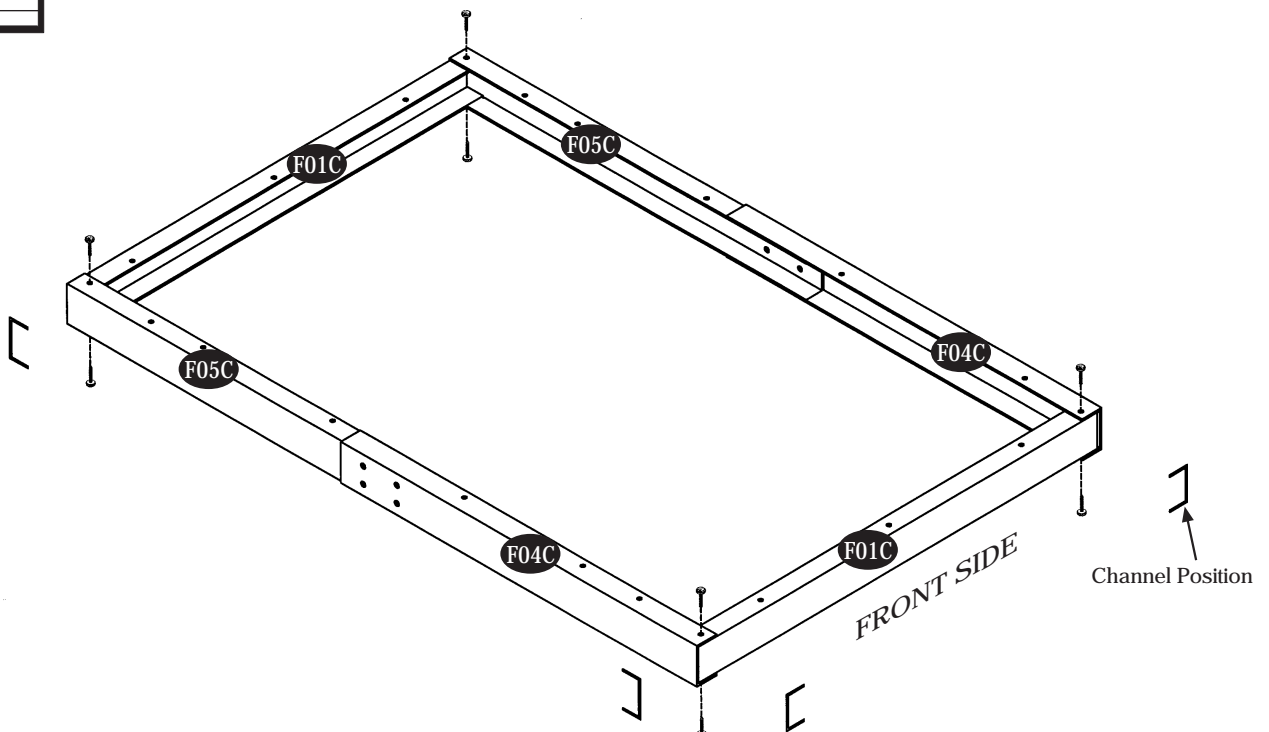

3. Fix the L-angle (F03) to the channel at all the four corners to make a perfect frame. See Fig.

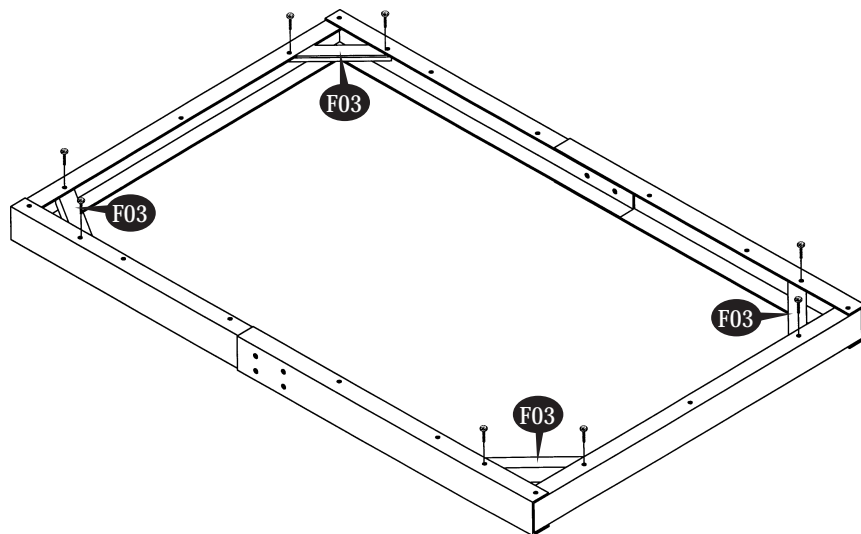

4. Fix the channel (F01C) into the main frame as shown. See Fig.



Make sure while assembling, the channel position should be as shown.

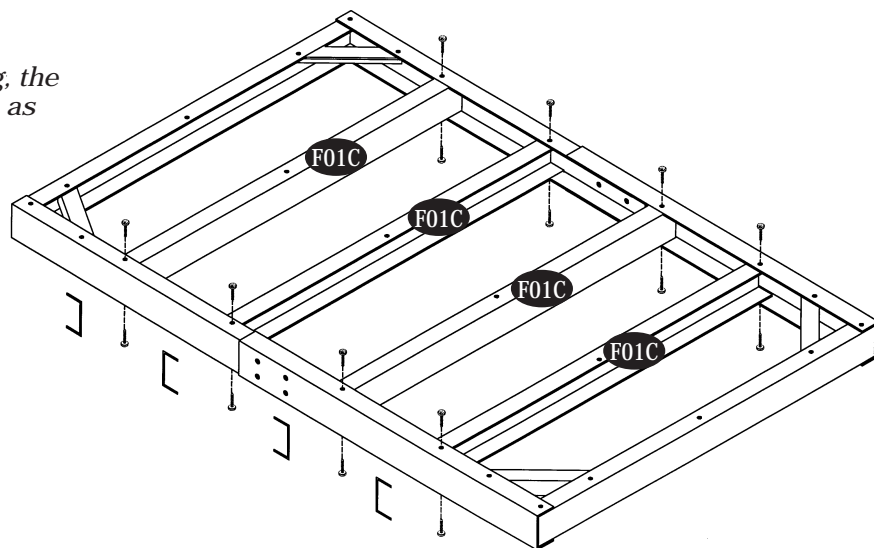

5. Fix the channel (F02C) into the frame with screws as shown. See Fig.

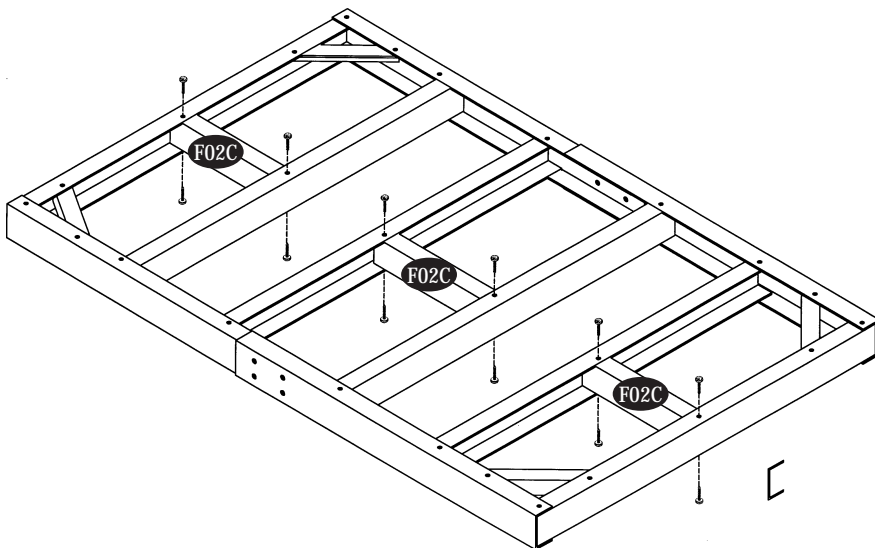

6. Assemble the U-Channel bases on top of the foundation as shown in Figure.

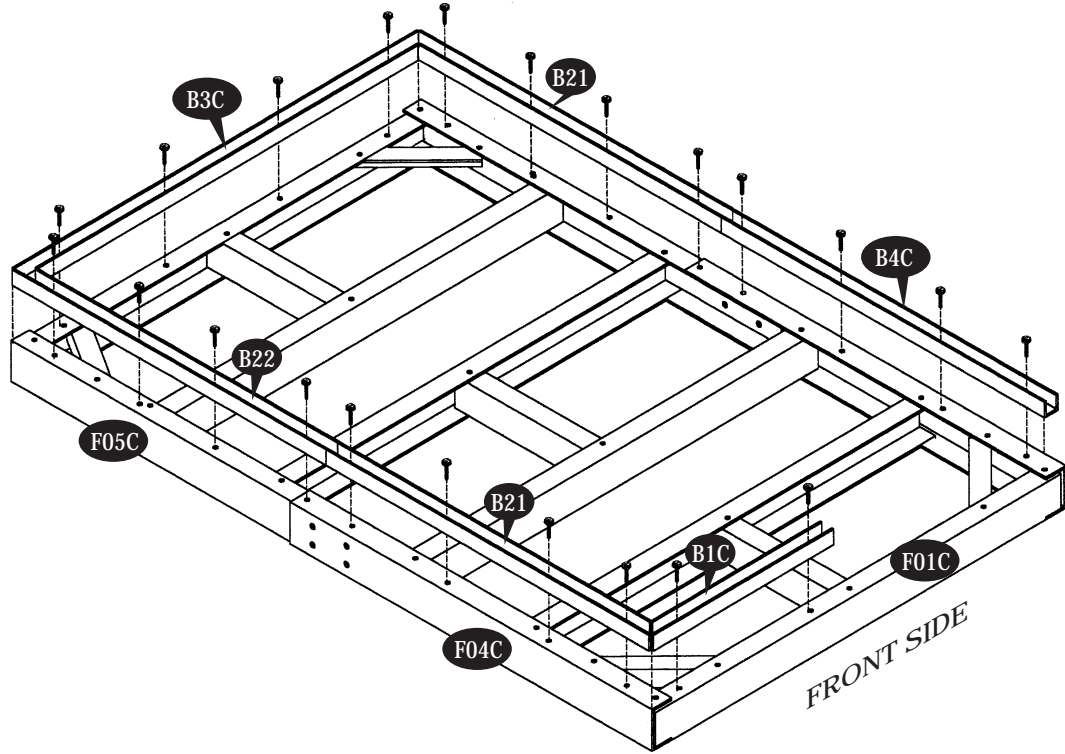

7a. After completing the assembly of shed place exterior grade CDX 3/4" (19mm) plywood inside the foundation. See fig.

OR 7b. After completing the assembly of the base U-channel fill the concrete upto the foundation top surface.

